

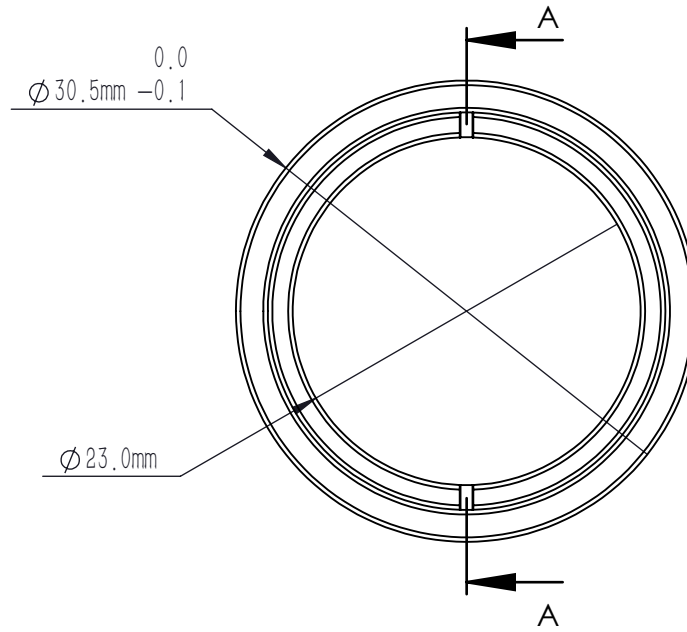

**MNDFA10-20-B**  
 $\Phi 25.4$  mm, OD=2.0  
 AR:700-1100 nm

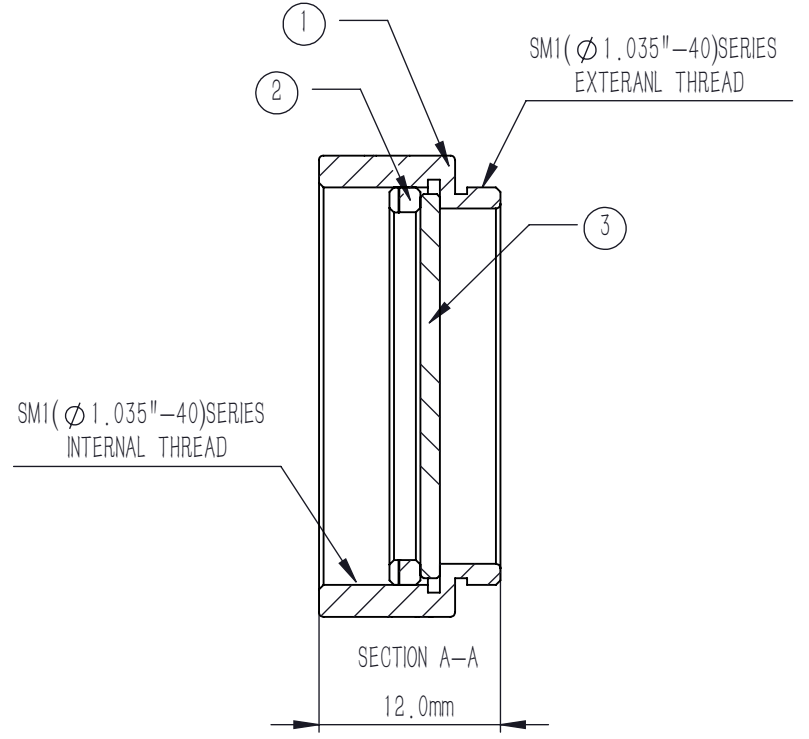

NUMBER	PART DESCRIPTION	MATERIAL
①	MECHANICAL HOUSING	BLACK ANODIZED ALUMINUM
②	SM1R	BLACK ANODIZED ALUMINUM
③	NDAFA10-20-B	ND Filter Glass



**NOTES**

1. OPERATION WAVELENGTH: 700 nm-1100 nm
2. OPTICAL DENSITY:  $2.0 \pm 0.10 @ 850$  nm
3. CLEAR APERTURE:  $>90\%$  CA
4. DIAMETER TOLERANCE:  $+0.00/-0.25$  mm
5. SURFACE QUALITY(S1,S2): 40/20(S/D)
6. SURFACE FLATNESS(S1,S2):  $\lambda/4 @ 632.8$  nm
7. PARALLELISM(S1,S2):  $<10$  arcsec
8. CHAMFER:  $<0.2$  mm,  $45^\circ$
9. COATING(S1): AR COATING,  $R_{avg} < 0.5\% @ 700$  nm-1100 nm,  $6^\circ$  AOI
10. OTHER SURFACES: FINE GROUND

DRAWING PROJECTION			<b>LBTEK</b>			
	NAME	DATE	MNDFA10-20-B			
DRAWN	LZHOU	JUN./7th/24	ABSORPTIVE NEUTRAL DENSITY FILTER SM1 LENS TUBE, OD=2.0, AR: 700 nm-1100 nm			
APPROVAL	WCHENG	JUN./7th/24	MATERIAL	WEIGHT	SCALE	REV
FOR INFORMATION ONLY NOT FOR MANUFACTURING PURPOSES			ND Filter Glass	8.1 g	2:1	B