

	PART DESCRIPTION	MATERIAL
①	SM1-8A	ANODIZED ALUMINIUM
②	NDFR10-03-C	N-BK7
③	SM1R	ANODIZED ALUMINIUM

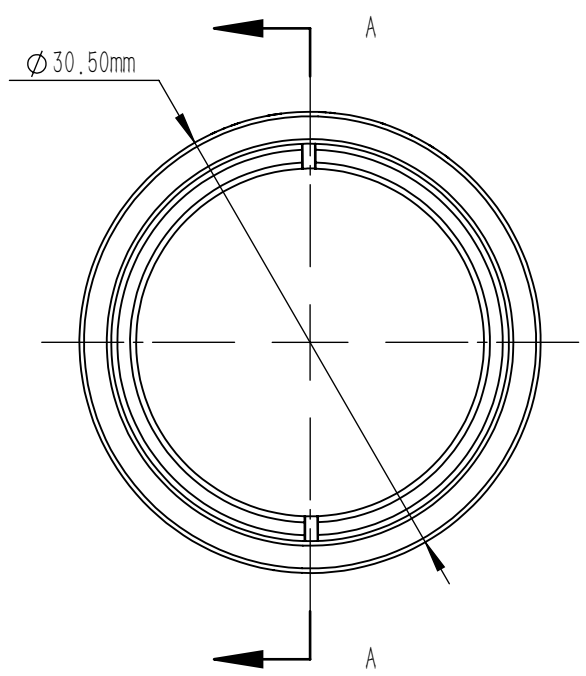
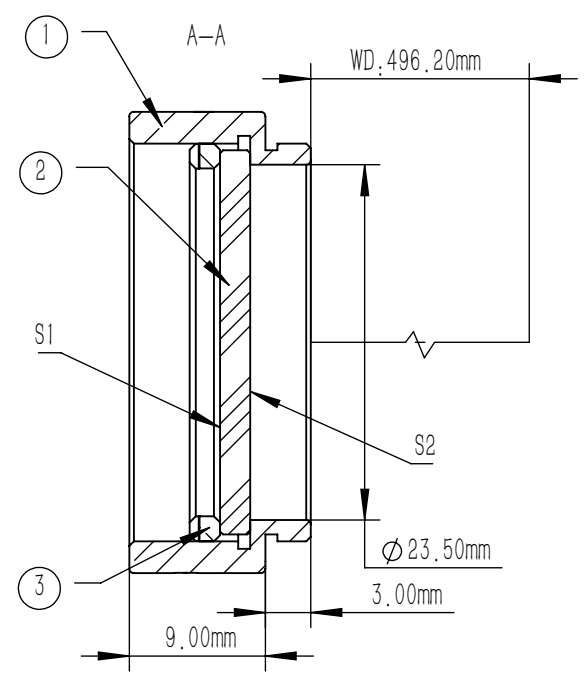

NOTES

1. OPERATION WAVELENGTH: 1100 nm-1700 nm
2. OPTICAL DENSITY(OD):  $0.3 \pm 0.015 @ 1100 \text{ nm}-1700 \text{ nm}$
3. CLEAR APERTURE:  $> 90\% \text{ CA}$
4. DIAMETER TOLERANCE:  $+0.00 / -0.25 \text{ mm}$
5. THICKNESS TOLERANCE:  $\pm 0.3 \text{ mm}$
6. COATING(S1): NiCrFe
7. SURFACE QUALITY(S1, S2): 40/20(S/D)
8. SURFACE FLATNESS(S1):  $\lambda / 2 @ 632.8 \text{ nm}$
9. PARALLELISM(S1, S2):  $< 30 \text{ arcsec}$
10. CHAMFER:  $< 0.2 \text{ mm}, 45^\circ$

DRAWING PROJECTION			<b>LBTEK</b>			
	NAME	DATE				
DRAWN	LTAN	2024/11/15	REFLECTIVE ND FILTER $\phi 25.4 \text{ mm}, \text{OD} = 0.3 @ 1100 \text{ nm}-1700 \text{ nm}$			
APPROVAL	WCHENG	2024/11/15	MATERIAL	WEIGHT	SCALE	REV
FOR INFORMATION ONLY NOT FOR MANUFACTURING PURPOSES			N-BK7	8.6 g	2:1	A