

$\phi 15.0\text{mm}$   
 [0.59in]  
 CLEAR APERTURE

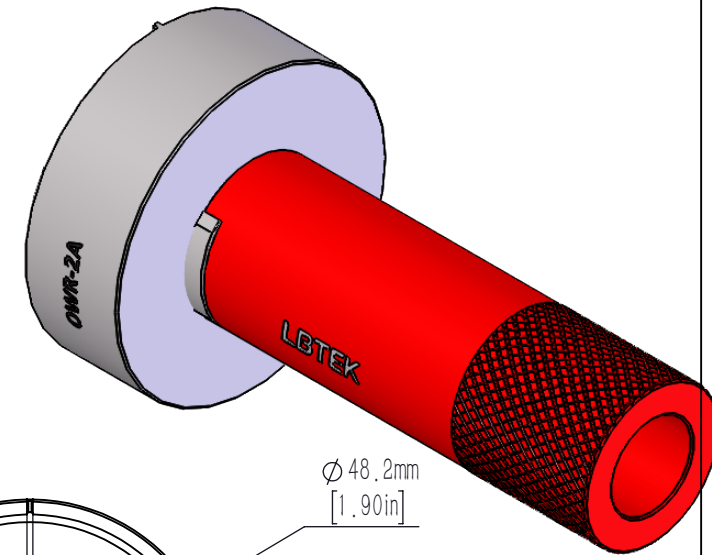
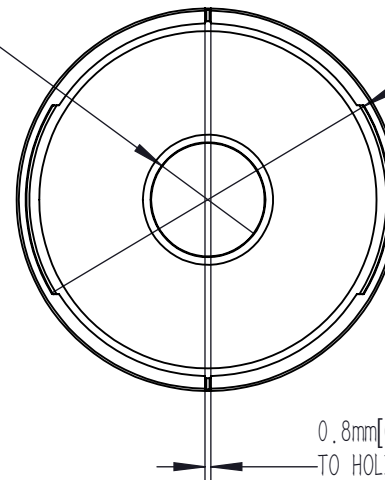

DRAWING PROJECTION			<b>LBTEK</b>			
	NAME	DATE				
DRAWN	ZHE	AUG./1st/19	SM2 SEREIS SPANNER WRENCH			
APPROVAL	ERIC	AUG./1st/19	MATERIAL	WEIGHT	SCALE	REV
FOR INFORMATION ONLY NOT FOR MANUFACTURING PURPOSES			N/A	0.15 Kg	1:1	C