

SPLITTING COATING(BEVEL FACE IN THE TRIANGULAR PRISM WITH DOT)

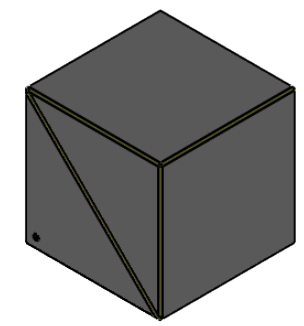
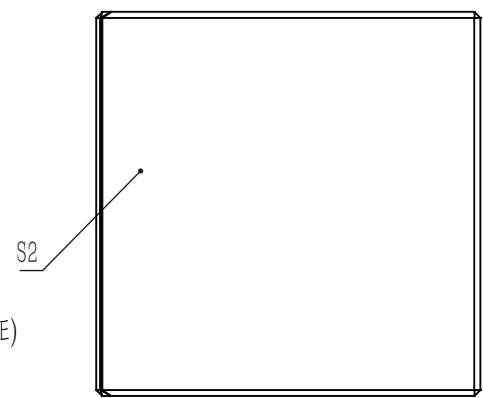
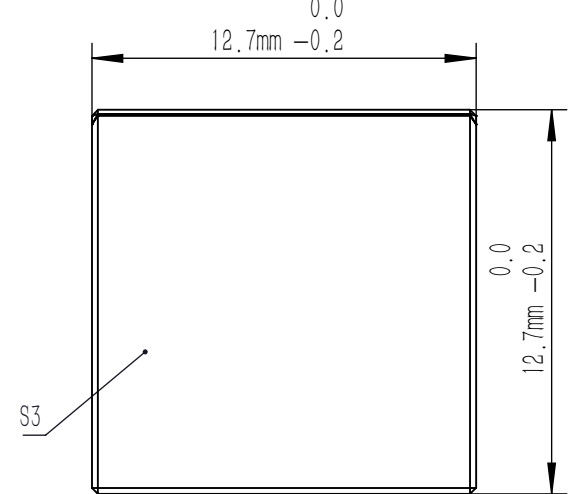

视图比例 2:1

NOTES

1. OPERATION WAVELENGTH: 1550 nm
2. CLEAR APERTURE: >80%CA
3. AR COATING(S1,S2,S3,S4): $R_{avg} < 0.25\%$ @1550 nm(6° AOI,SINGLE SURFACE)
4. ANGLE TOLERANCE: $\pm 1'$
5. COATING(S5): $T_p > 95\%$, $R_s > 99.5\%$
6. GLUED(S5,S6): NOA61
7. EXTINCTION RATIO($T_p:T_s$): >3000:1
8. TRANSMITTED BEAM DEVIATION: $0^\circ \pm 5$ arcmin
9. REFLECTED BEAM DEVIATION: $90^\circ \pm 5$ arcmin
10. SURFACE QUALITY(S1,S2,S3,S4): 40/20(S/D)
11. WAVEFRONT ERROR(RMS): $\lambda/4@633$ nm
12. SURFACE FLATNESS(S1,S2,S3,S4): $\lambda/4@633$ nm
13. OTHER SURFACES: FINE GROUND
14. CHAMFER: 0.2 mm, 45°

DRAWING PROJECTION			LBTEK			
	NAME	DATE				
DRAWN	LTAN	Aug./31st/25	LASER LINE POLARIZATION BEAM SPLITTER L=12.7 mm, $T_p:T_s > 3000:1@1550$ nm			
APPROVAL	WCHENG	Aug./31st/25	MATERIAL	WEIGHT	SCALE	REV
FOR INFORMATION ONLY NOT FOR MANUFACTURING PURPOSES			UVFS	4.5 g	4:1	C