

BEAM SPLITTING COATING(BEVEL FACE IN THE TRIANGULAR PRISM WITH DOT)

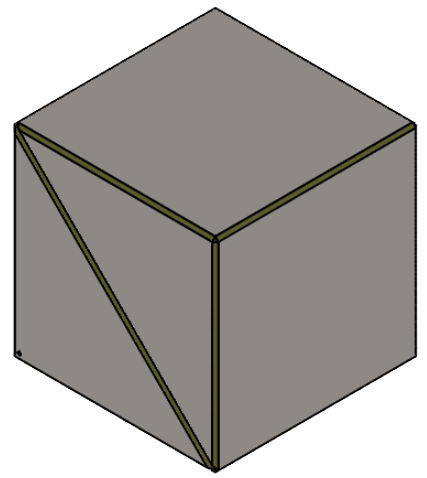
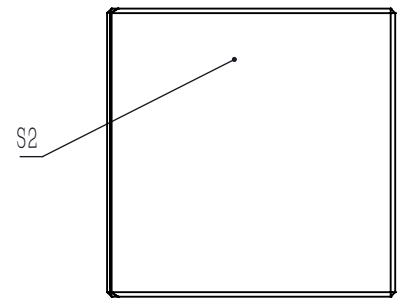

NOTES

1. CLEAR APERTURE: >80% WxL
2. DIAMETER TOLERANCE: +0.0/-0.2 mm
3. EXTINCTION RATIO(Tp:Ts): >2000:1
4. DESIGN WAVELENGTH: 355 nm
5. TRANSMITTED BEAM DEVIATION: ≤0° ±5 arcmin
6. REFLECTED BEAM DEVIATION: ≤90° ±5 arcmin
7. SURFACE QUALITY(S/D): 40/20
8. WAVEFRONT ERROR(RMS): < λ/4@633 nm
9. PARALLELISM(S1,S2,S3,S4): ≤10 arcsec
10. AR COATING(S1,S2,S3,S4): V Coating @355 nm, Rabs<0.25%, 6° AOI, single face
11. S POLARIZATION REFLECTION: >99.5%
12. P POLARIZATION TRANSMISSION: >95%
13. CHAMFER: <0.5 mm x 45°
14. OPERATING TEMPERATURE: -50C° ~90C°
15. GLUED(S5,S6): LIGHT GLUE PROCESS

DRAWING PROJECTION			<b>LBTEK</b>			
	NAME	DATE	PBS22-355-HP			
DRAWN	LTAN	Aug./31st/25	LASER LINE POLARIZATION BEAM SPLITTER L=12.7 mm, Tp: Ts>2000:1@355 nm			
APPROVAL	WCHENG	Aug./31st/25	MATERIAL	WEIGHT	SCALE	REV
FOR INFORMATION ONLY NOT FOR MANUFACTURING PURPOSES			UVFS	4.5 g	3:1	B