

BEAM SPLITTING COATING(BEVEL FACE IN THE TRIANGULAR PRISM WITH DOT)

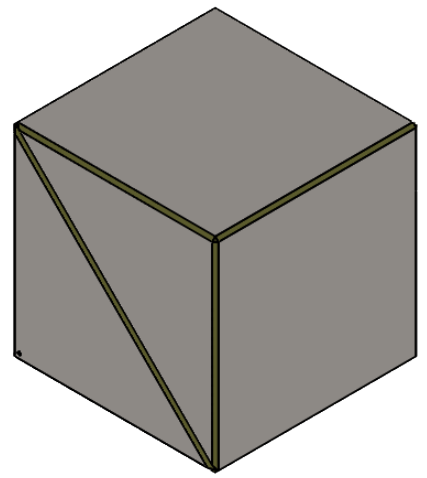
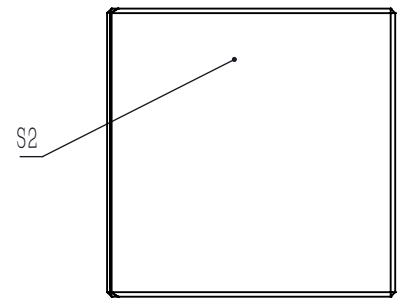

NOTES

1. CLEAR APERTURE: >80% WxL
2. DIAMETER TOLERANCE: +0.0/-0.2 mm
3. EXTINCTION RATIO(Tp:Ts): >2000:1
4. DESIGN WAVELENGTH: 808 nm
5. TRANSMITTED BEAM DEVIATION: ≤0° ±5 arcmin
6. REFLECTED BEAM DEVIATION: ≤90° ±5 arcmin
7. SURFACE QUALITY(S/D): 20/10
8. WAVEFRONT ERROR(RMS): <λ/4@633 nm
9. PARALLELISM(S1,S2,S3,S4): ≤10 arcsec
10. AR COATING(S1,S2,S3,S4): V Coating @808 nm, Rabs<0.25%, 6° AOI, single face
11. S POLARIZATION REFLECTION: >99.5%
12. P POLARIZATION TRANSMISSION: >97%
13. CHAMFER: <0.5 mm x 45°
14. OPERATING TEMPERATURE: -50C° ~90C°
15. GLUED(S5,S6): LIGHT GLUE PROCESS

DRAWING PROJECTION			LBTEK			
	NAME	DATE				
DRAWN	LZHOU	Aug./12th/24	LASER LINE POLARIZATION BEAM SPLITTER L=12.7 mm, Tp:Ts>2000:1@808 nm			
APPROVAL	WCHENG	Aug./12th/24	MATERIAL	WEIGHT	SCALE	REV
FOR INFORMATION ONLY NOT FOR MANUFACTURING PURPOSES			UVFS	4.5 g	3:1	A