

SPLITTING COATING(BEVEL FACE IN THE TRIANGULAR PRISM WITH DOT)

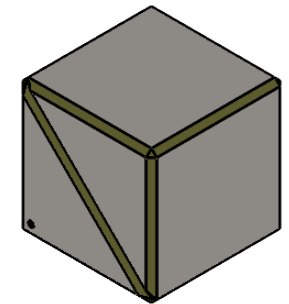
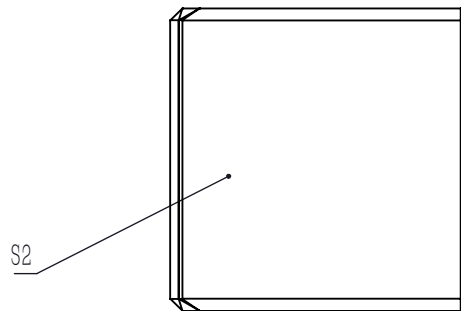

NOTES

1. CLEAR APERTURE: >80%CA
2. AR COATING(S1,S2,S3,S4): RAVG<0.5% @620 nm-1000 nm(6° AOI,SINGLE SURFACE)
3. DIAMETER TOLERANCE: ±0.25 mm
4. ANGLE TOLERANCE: ±1'
5. COATING(S5): Tp>90%, Rs,avg>95%
6. GLUED(S5,S6): NOA61
7. EXTINCTION RATIO(Tp:Ts): >1000:1
8. TRANSMITTED BEAM DEVIATION: 0° ± 5 arcmin
9. REFLECTED BEAM DEVIATION: 90° ± 5 arcmin
10. SURFACE QUALITY(S1,S2,S3,S4): 40/20(S/D)
11. WAVEFRONT ERROR(RMS): λ/4@633 nm
12. SURFACE FLATNESS(S1,S2,S3,S4): λ/4@633 nm
13. OTHER SURFACES: FINE GROUND
14. CHAMFER: <0.2 mm,45°

DRAWING PROJECTION			<b>LBTEK</b>			
	NAME	DATE				
DRAWN	LTAN	Aug./31st/25	POLARIZATION BEAM SPLITTER L=5 mm, Tp:Ts>1000:1@620 nm-1000 nm			
APPROVAL	WCHENG	Aug./31st/25	MATERIAL	WEIGHT	SCALE	REV
FOR INFORMATION ONLY NOT FOR MANUFACTURING PURPOSES			N-SF1	0.4 g	8:1	B