

SPLITTING COATING(BEVEL FACE IN THE TRIANGULAR PRISM WITH DOT)

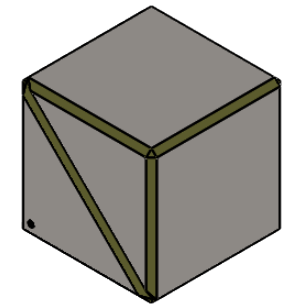
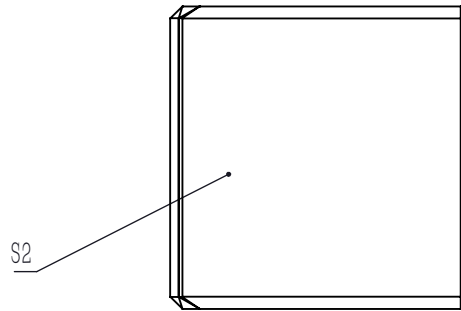

NOTES

1. CLEAR APERTURE: >80%CA
2. AR COATING(S1,S2,S3,S4):  $R_{avg} < 0.5\%$  @900 nm-1300 nm(6° AOI,SINGLE SURFACE)
3. DIAMETER TOLERANCE:  $\pm 0.25$  mm
4. ANGLE TOLERANCE:  $\pm 1'$
5. COATING(S5):  $T_p > 90\%$ ,  $R_{s,avg} > 95\%$
6. GLUED(S5,S6): NOA61
7. EXTINCTION RATIO( $T_p:T_s$ ): >1000:1
8. TRANSMITTED BEAM DEVIATION:  $0^\circ \pm 5$  arcmin
9. REFLECTED BEAM DEVIATION:  $90^\circ \pm 5$  arcmin
10. SURFACE QUALITY(S1,S2,S3,S4): 40/20(S/D)
11. WAVEFRONT ERROR(RMS):  $\lambda/4@633$  nm
12. SURFACE FLATNESS(S1,S2,S3,S4):  $\lambda/4@633$  nm
13. OTHER SURFACES: FINE GROUND
14. CHAMFER: <0.2 mm,45°

DRAWING PROJECTION			<b>LBTEK</b>			
	NAME	DATE				
DRAWN	LTAN	Aug./31st/25	POLARIZATION BEAM SPLITTER L=5 mm, $T_p:T_s > 1000:1@900$ nm-1300 nm			
APPROVAL	WCHENG	Aug./31st/25	MATERIAL	WEIGHT	SCALE	REV
FOR INFORMATION ONLY NOT FOR MANUFACTURING PURPOSES			N-SF1	0.4 g	8:1	B