

SPLITTING COATING(BEVEL FACE IN THE TRIANGULAR PRISM WITH DOT)

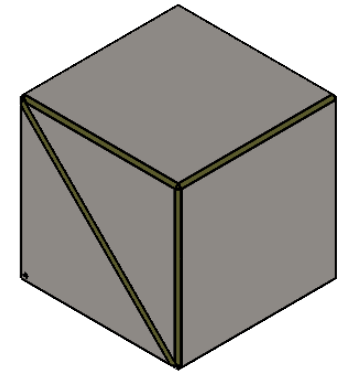
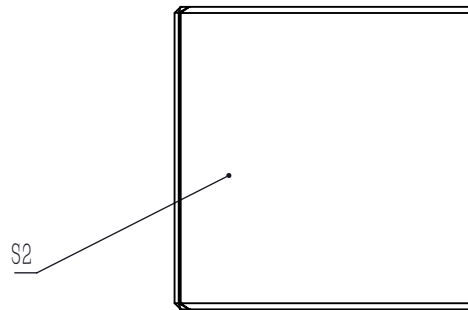
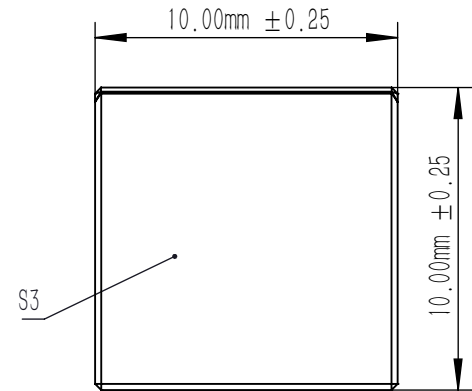

NOTES

1. CLEAR APERTURE: >80%CA
2. AR COATING(S1,S2,S3,S4): $R_{avg} < 0.5\%$ @900 nm-1300 nm(6° AOI,SINGLE SURFACE)
3. DIAMETER TOLERANCE: ± 0.25 mm
4. ANGLE TOLERANCE: $\pm 1'$
5. COATING(S5): $T_p > 90\%$, $R_s, avg > 95\%$
6. GLUED(S5,S6): NOA61
7. EXTINCTION RATIO(T_p, T_s): $> 1000:1$
8. TRANSMITTED BEAM DEVIATION: $0^\circ \pm 5$ arcmin
9. REFLECTED BEAM DEVIATION: $90^\circ \pm 5$ arcmin
10. SURFACE QUALITY(S1,S2,S3,S4): 40/20(S/D)
11. WAVEFRONT ERROR(RMS): $\lambda/4 @ 633$ nm
12. SURFACE FLATNESS(S1,S2,S3,S4): $\lambda/4 @ 633$ nm
13. OTHER SURFACES: FINE GROUND
14. CHAMFER: < 0.2 mm, 45°

DRAWING PROJECTION			LBTEK			
	NAME	DATE				
DRAWN	LTAN	Aug./31st/25	POLARIZATION BEAM SPLITTER L=10 mm, $T_p, T_s > 1000:1 @ 900$ nm-1300 nm			
APPROVAL	WCHENG	Aug./31st/25	MATERIAL	WEIGHT	SCALE	REV
FOR INFORMATION ONLY NOT FOR MANUFACTURING PURPOSES			N-SF1	3.0 g	4:1	B