

SPLITTING COATING(BEVEL FACE IN THE TRIANGULAR PRISM WITH DOT)

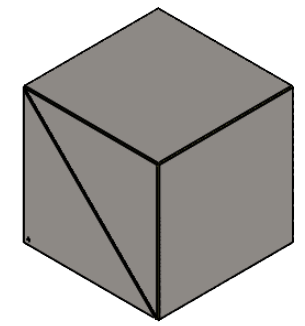
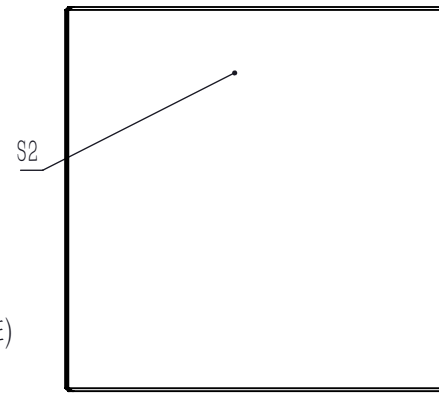
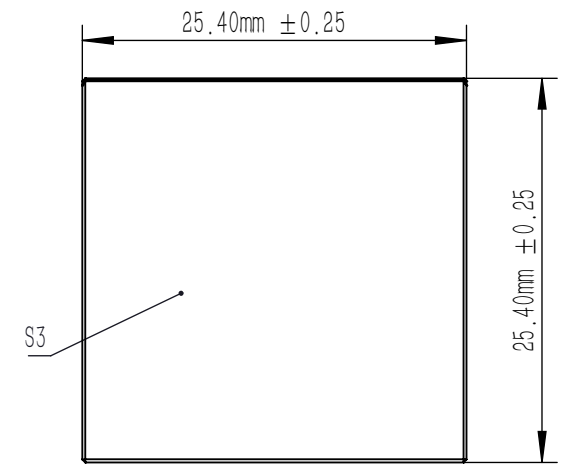
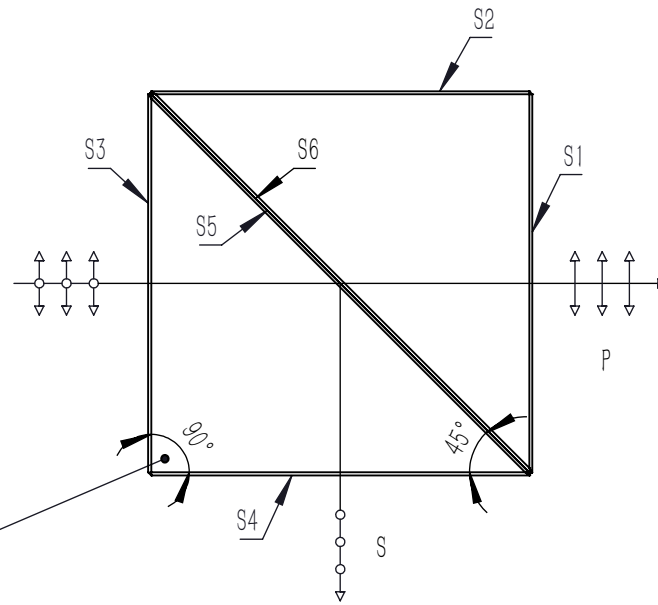

NOTES

1. CLEAR APERTURE: >80%CA
2. AR COATING(S1,S2,S3,S4): $R_{avg} < 0.5\%$ @900 nm-1300 nm(6° AOI,SINGLE SURFACE)
3. DIAMETER TOLERANCE: ± 0.25 mm
4. ANGLE TOLERANCE: $\pm 1'$
5. COATING(S5): $T_p > 90\%$, $R_{s,avg} > 95\%$
6. GLUED(S5,S6): NOA61
7. EXTINCTION RATIO($T_p:T_s$): >1000:1
8. TRANSMITTED BEAM DEVIATION: $0^\circ \pm 5$ arcmin
9. REFLECTED BEAM DEVIATION: $90^\circ \pm 5$ arcmin
10. SURFACE QUALITY(S1,S2,S3,S4): 40/20(S/D)
11. WAVEFRONT ERROR(RMS): $\lambda/4@633$ nm
12. SURFACE FLATNESS(S1,S2,S3,S4): $\lambda/4@633$ nm
13. OTHER SURFACES: FINE GROUND
14. CHAMFER: <0.2 mm,45°

DRAWING PROJECTION			LBTEK			
	NAME	DATE				
DRAWN	LTAN	Aug./24th/25	POLARIZATION BEAM SPLITTER L=25.4 mm, $T_p:T_s > 1000:1@900$ nm-1300 nm			
APPROVAL	WCHENG	Aug./24th/25	MATERIAL	WEIGHT	SCALE	REV
FOR INFORMATION ONLY NOT FOR MANUFACTURING PURPOSES			N-SF1	49.6 g	2:1	B