

ARROW POINTS TO THE INCIDENT SURFACE

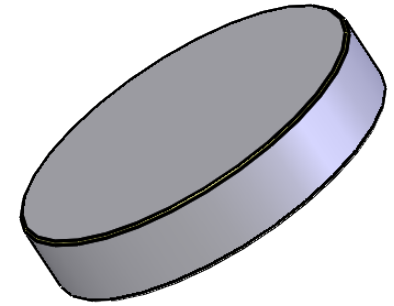

NOTES

1. MATERIAL: UVFS
2. CLEAR APERTURE: >90%
3. DESIGN WAVELENGTH: 808 nm
4. DIAMETER TOLERANCE: +0.0/-0.1 mm
5. THICKNESS TOLERANCE: ±0.1 mm
6. EXTINCTION RATIO: >10000: 1
7. SURFACE QUALITY(S/D): 40/20
8. WAVEFRONT ERROR(RMS): $\lambda/8@632.8 \text{ nm}$
9. SURFACE FLATNESS: $\lambda/4@632.8 \text{ nm}$
10. SPILTTING COATING(S1,S2): POLARIZATION SPILTTING COATING
 P POLARIZATION TRANSMISSION: $T_p > 93\% @ 808 \text{ nm}$,
 S POLARIZATION TRANSMISSION: $T_s < 0.5\% @ 808 \text{ nm}$, AOI 45°
11. CHAMFER: 45° , <0.2 mm

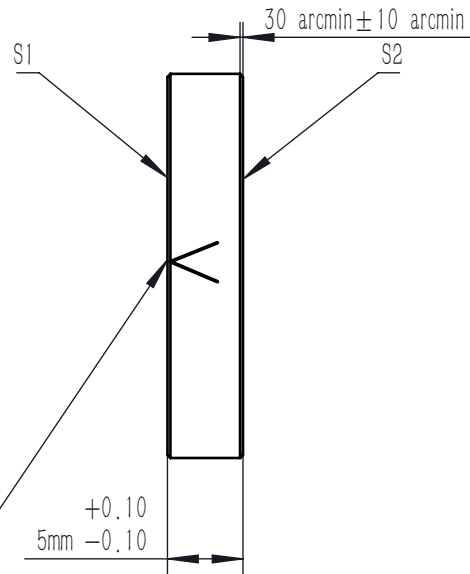
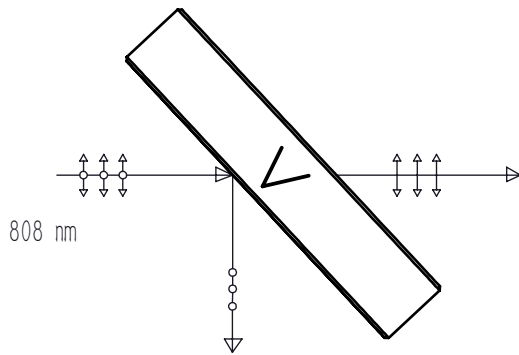

DRAWING PROJECTION			LBTEK			
NAME	DATE					
DRAWN	LZHOU	Aug./12th/24	POLARIZATION FLAT BEAM SPLITTER $\text{Ø} 25.4 \text{ mm} \times 5 \text{ mm}, 808 \text{ nm}$			
APPROVAL	WCHENG	Aug./12th/24	MATERIAL	WEIGHT	SCALE	REV
FOR INFORMATION ONLY NOT FOR MANUFACTURING PURPOSES			UVFS	5.6 g	2:1	A