

Pin screw for additional locking of the fiber ferrule.

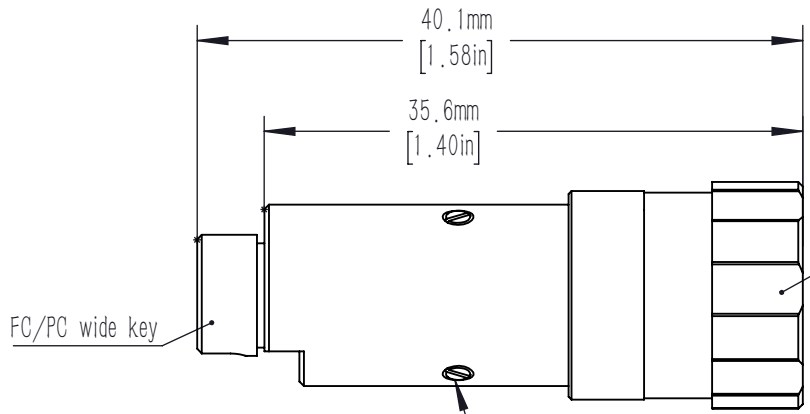
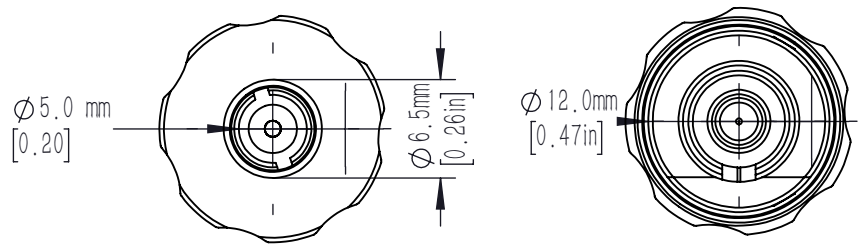

adjustment of focus setting

FC/PC wide key

clamp screws for locking optics position (2x120°)

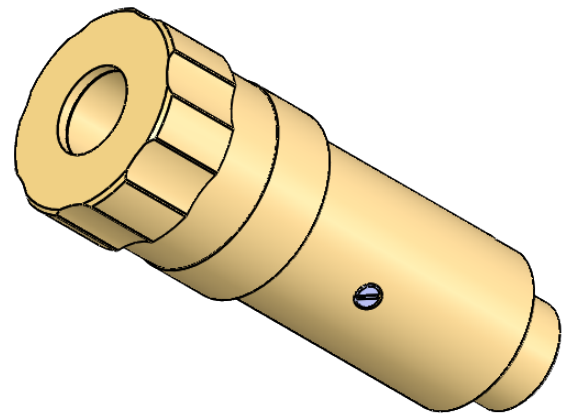

- notes,
- 1.focal length: 11 mm
 - 2.Waist beam spot diameter: 2.14 mm@ 1550 nm SMF28e
 - 3.Interface type: FC/PC
 - 4.Lens type: Aspheric lens
 - 5.Collimation divergence angle: $\leq 0.056^\circ$
 - 6.Lens coating: $R_{avg} \leq 0.5\% @ 1050 - 1700 \text{ nm}$

DRAWING PROJECTION							
	NAME	DATE	PRACFCD-11-C-PC				
DRAWN	BSHU	2026/2/4	FIBER COLLIMATOR				
APPROVAL	WCHENG	2026/2/4	MATERIAL	WEIGHT	SCALE	REV	
FOR INFORMATION ONLY NOT FOR MANUFACTURING PURPOSES			Silicon brass	29 g	2:1	A	