

Pin screw for additional locking of the fiber ferrule.

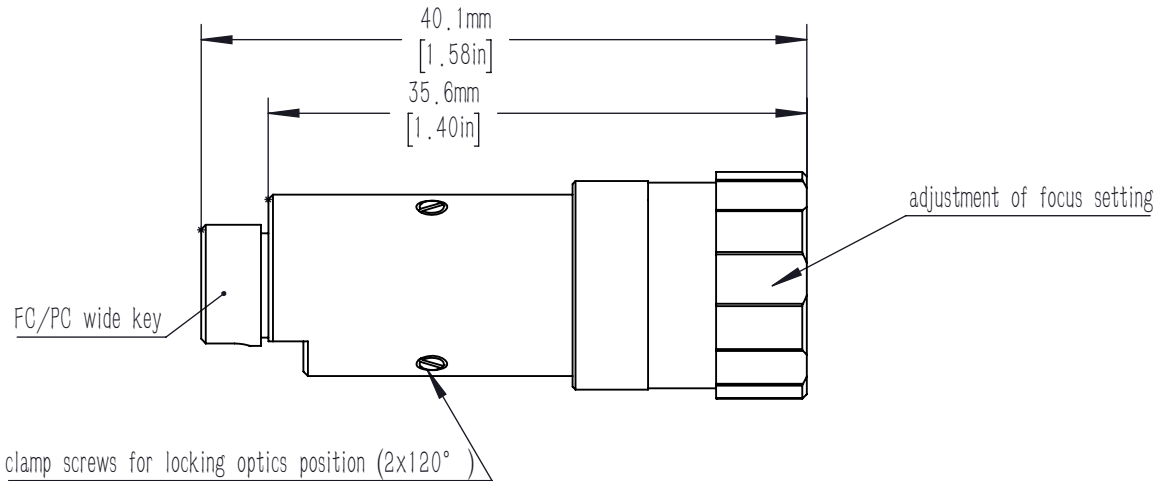
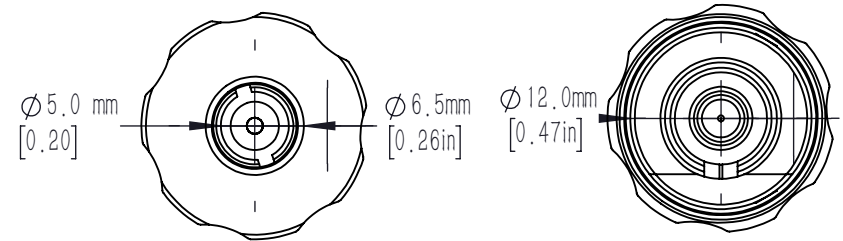

FC/PC wide key

adjustment of focus setting

clamp screws for locking optics position (2x120°)

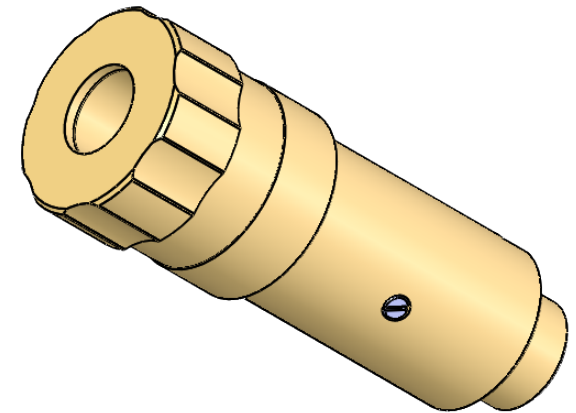

notes.

- 1.focal length: 7.5 mm
- 2.Waist beam spot diameter: 1.62 mm@ 850 nm 780HP
- 3.Interface type: FC/PC
- 4.Lens type: Aspheric lens
- 5.Collimation divergence angle: $\leq 0.044^\circ$
- 6.Lens coating: $R_{\text{avg}} \leq 0.5\% @ 600 - 1050\text{ nm}$

DRAWING PROJECTION							
	NAME	DATE	PRACFCD-7.5-B-PC				
DRAWN	BSHU	2026/2/9	FIBER COLLIMATOR				
APPROVAL	WCHENG	2026/2/9	MATERIAL	WEIGHT	SCALE	REV	
FOR INFORMATION ONLY NOT FOR MANUFACTURING PURPOSES			Silicon brass	29 g	2:1	A	