

Pin screw for additional locking of the fiber ferrule.

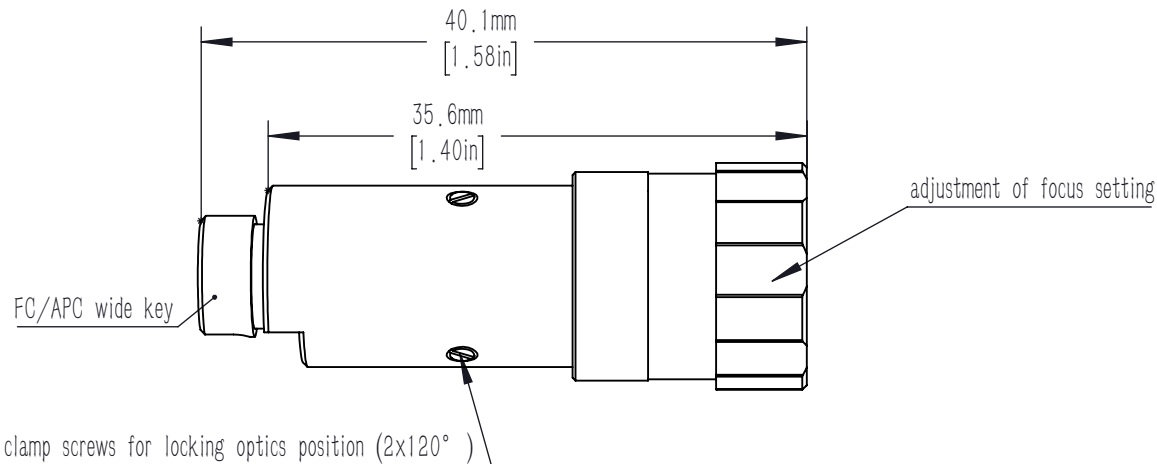
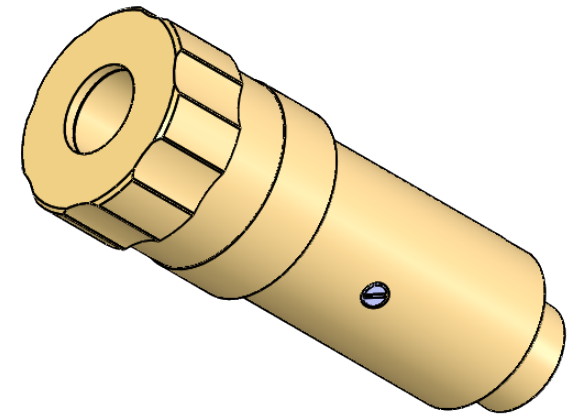
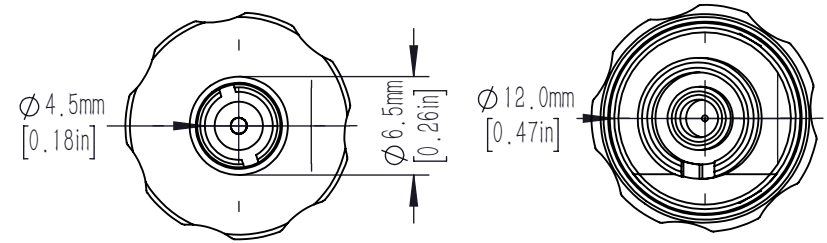

notes.

- 1.focal length: 11 mm
- 2.Waist beam spot diameter: 2.09 mm@ 1550 nm SMF28E
- 3.Interface type: FC/APC
- 4.Lens type: Double glued achromatic lens
- 5.Collimation divergence angle:  $\leq 0.056^\circ$
- 6.Lens coating:  $R_{\text{avg}} \leq 0.5\% @ 1050 - 1650 \text{ nm}$

DRAWING PROJECTION			<b>LBTEK</b>			
	NAME	DATE				
DRAWN	BSHU	2025/9/23	FIBER COLLIMATOR			
APPROVAL	WCHENG	2025/9/23	MATERIAL	WEIGHT	SCALE	REV
FOR INFORMATION ONLY NOT FOR MANUFACTURING PURPOSES			Silicon brass	29 g	2:1	A