

Pin screw for additional locking of the fiber ferrule.

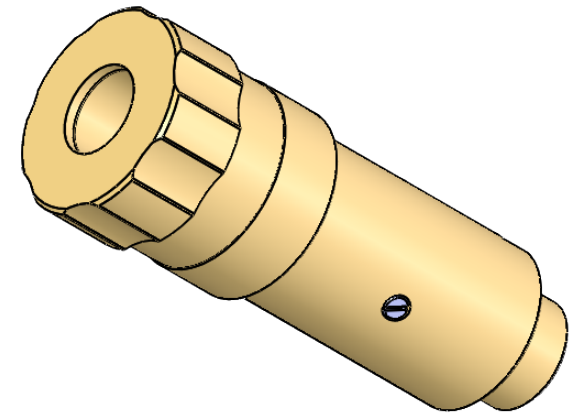
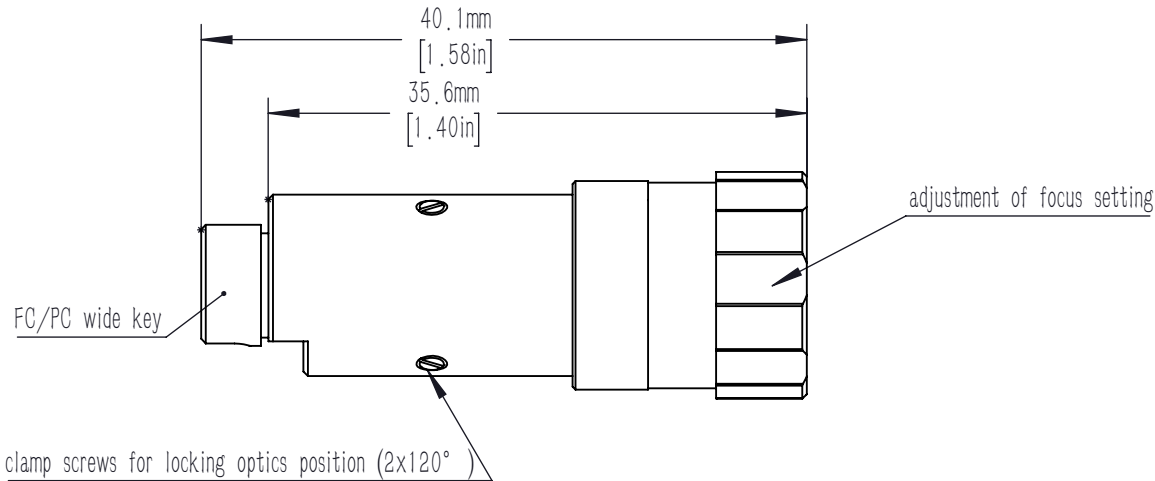
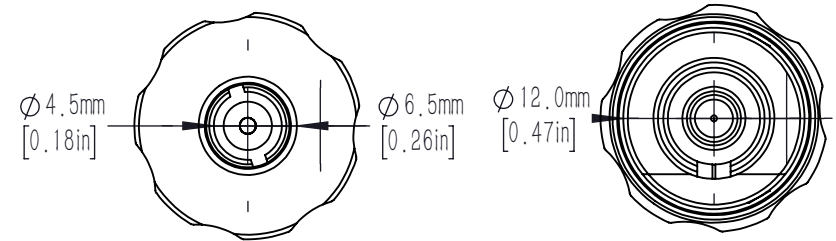

notes.

- 1.focal length: 7.5 mm
- 2.Waist beam spot diameter: 1.63 mm@ 850 nm 780HP
- 3.Interface type: FC/PC
- 4.Lens type: Double glued achromatic lens
- 5.Collimation divergence angle:  $\leq 0.044^\circ$
- 6.Lens coating:  $R_{\text{avg}} \leq 0.5\% @ 700 - 1100 \text{ nm}$

DRAWING PROJECTION			<b>LBTEK</b>			
NAME	DATE	PRADFCD-7.5-B-PC				
DRAWN	BSHU	2025/9/8	FIBER COLLIMATOR			
APPROVAL	WCHENG	2025/9/8	MATERIAL	WEIGHT	SCALE	REV
FOR INFORMATION ONLY NOT FOR MANUFACTURING PURPOSES			Silicon brass	29 g	2:1	A