

Pin screw for additional locking of the fiber ferrule.

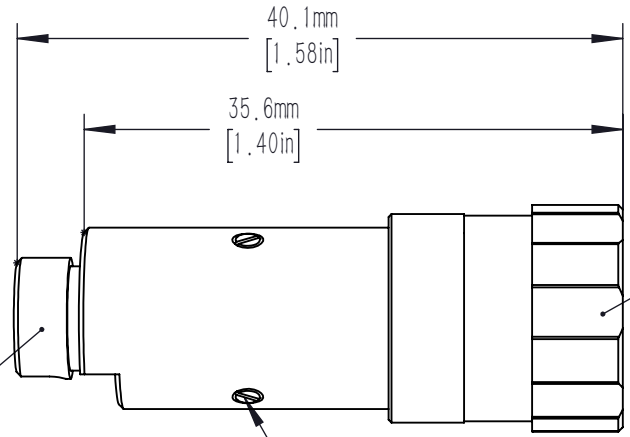
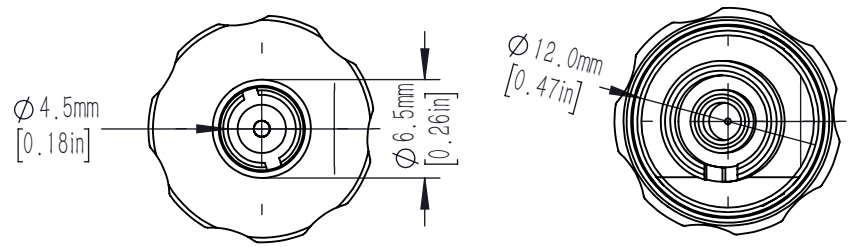

adjustment of focus setting

FC/APC wide key

clamp screws for locking optics position (2x120°)

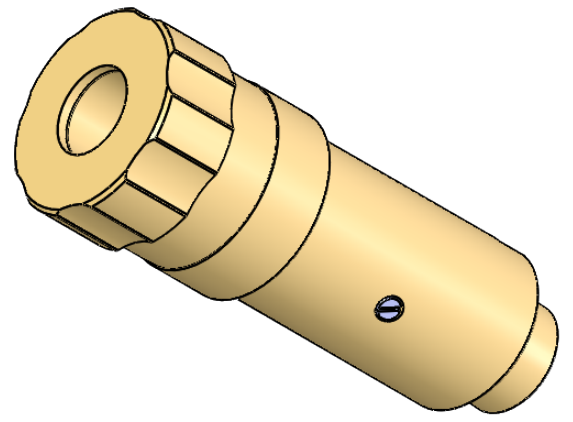

- notes:
- 1.focal length: 7.5 mm
 - 2.Waist beam spot diameter: 1.43 mm@ 1550 nm SMF28E
 - 3.Interface type: FC/APC
 - 4;Lens type: Double glued achromatic lens
 - 5;Collimation divergence angle: $\leq 0.08^\circ$
 - 6.Lens coating: $R_{avg} \leq 0.5\% @ 1050 - 1650 \text{ nm}$

DRAWING PROJECTION			LBTEK			
	NAME	DATE				
DRAWN	BSHU	2025/9/23	FIBER COLLIMATOR			
APPROVAL	WCHENG	2025/9/23	MATERIAL	WEIGHT	SCALE	REV
FOR INFORMATION ONLY NOT FOR MANUFACTURING PURPOSES			Silicon brass	29 g	2:1	A