

Ø 1.2 HOLES
FOR USE WITH OWR-U
SPANNER WRENCHES (NOT INCLUDED)
4 PLACES, 2 PER SIDE

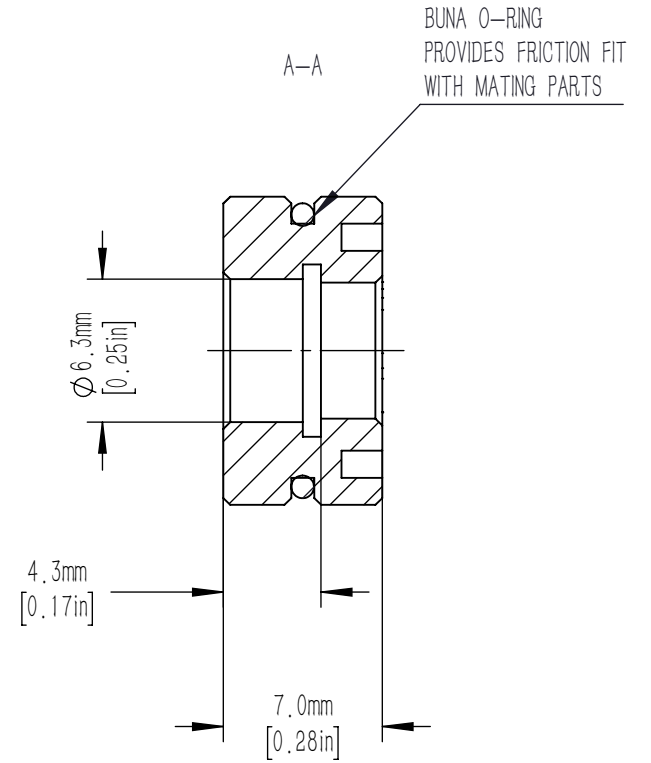
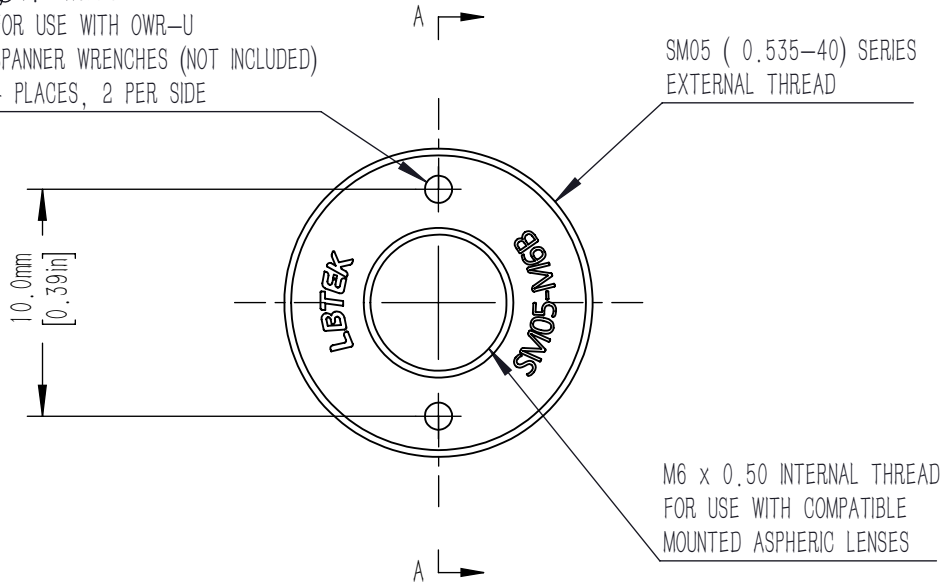

DRAWING PROJECTION			LBTEK			
NAME	DATE	SM05-M6B				
DRAWN	SSO	MAR./6th/24	SM05 TO M6 LENS ADAPTER			
APPROVAL	HDE	MAR./6th/24	MATERIAL	WEIGHT	SCALE	REV
FOR INFORMATION ONLY NOT FOR MANUFACTURING PURPOSES			N/A	0.002 Kg	3:1	A