

SPANNER SLOT FOR
USING WITH OWR-1A

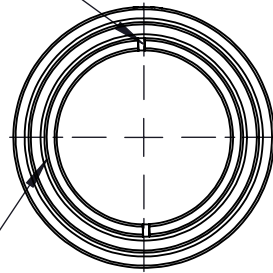

SM1 (Ø 1.035-40) SERIES
INTERNAL THREAD
25mm[0.98in] DEEP
2 SM1R RETAINING RING INCLUDED
Ø 23.0mm[Ø 0.91in] CLEAR APERTURE

SM1 (Ø 1.035-40) SERIES
EXTERNAL THREAD

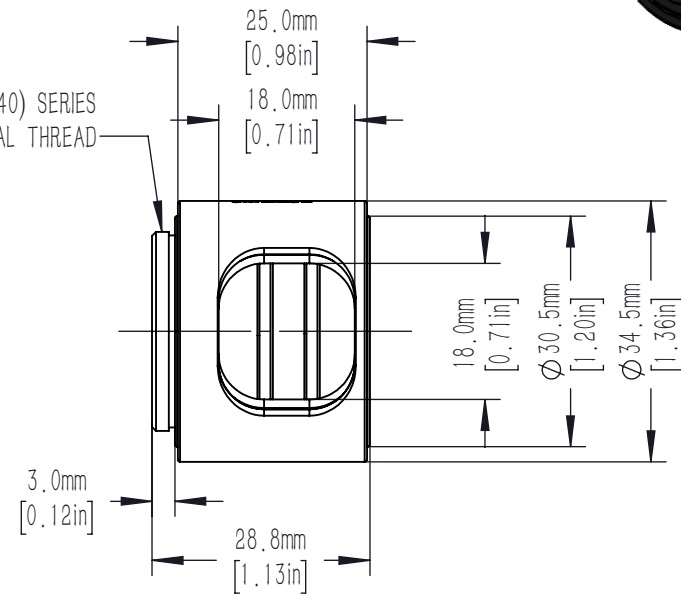

DRAWING PROJECTION			LBTEK			
	NAME	DATE				
DRAWN	KZH	OCT./24th/22	SM1 SLOTTED LENS TUBE WITH DUST COVER, 25mm DEEP			
APPROVAL	ZXU	OCT./24th/22	MATERIAL	WEIGHT	SCALE	REV
FOR INFORMATION ONLY NOT FOR MANUFACTURING PURPOSES			N/A	0.023 Kg	1:1	B