

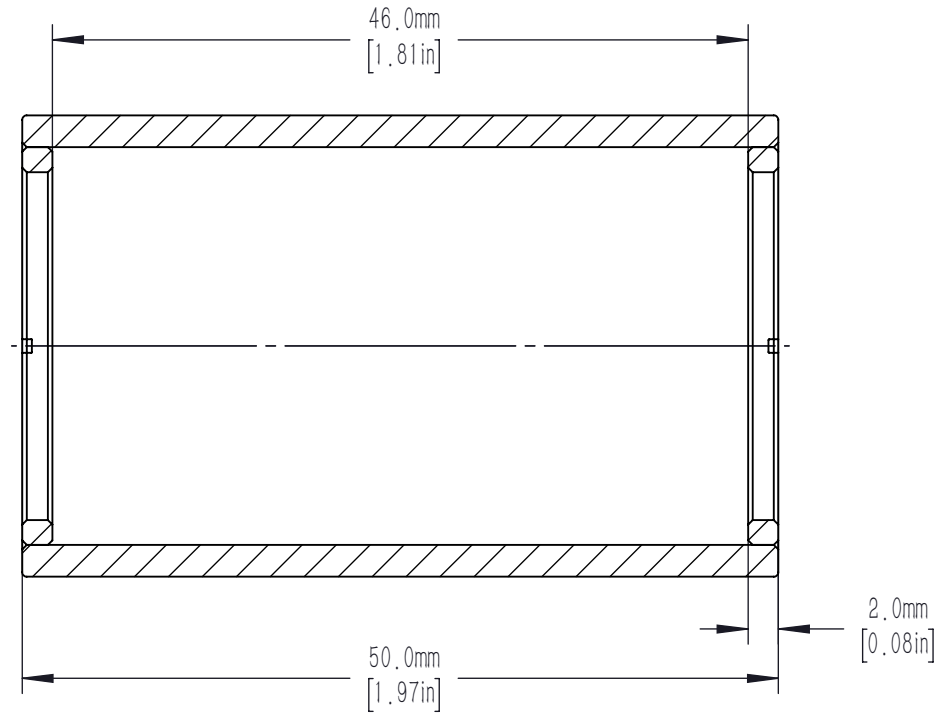

A-A

SPANNER WRENCH SLOTS
FOR USING WITH OWR-1A

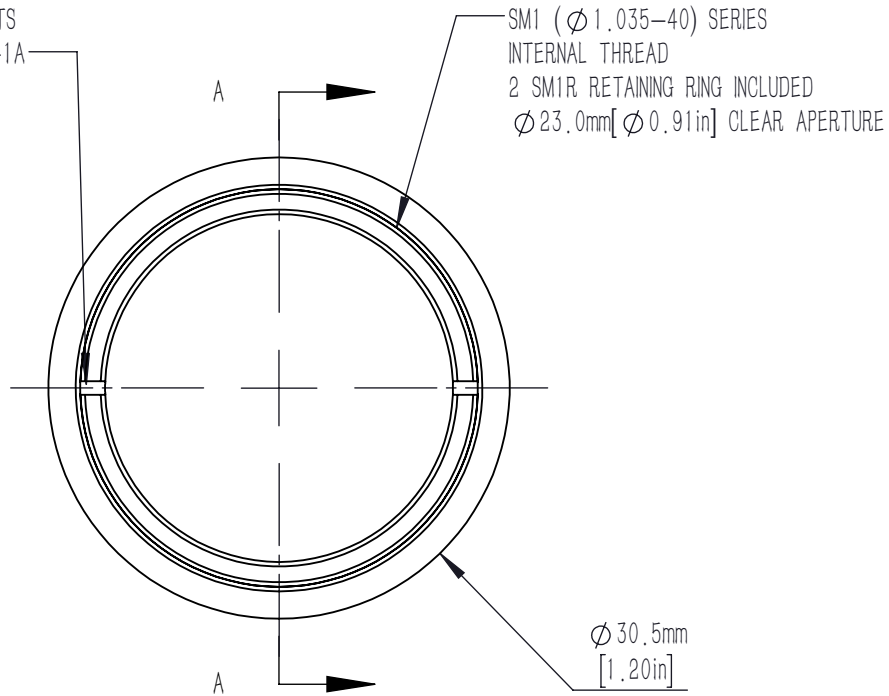

DRAWING PROJECTION			LBTEK			
	NAME	DATE	SM1-50B			
DRAWN	YCH	MAR./6th/20	SM1 INTERNAL THREAD LENS TUBE SLEEVE ,50mm LENGTH			
APPROVAL	LDAI	MAR./6th/20	MATERIAL	WEIGHT	SCALE	REV
FOR INFORMATION ONLY NOT FOR MANUFACTURING PURPOSES			N/A	0.03 Kg	2:1	B