

SM1 (EXT 1.035"-40) SERIES
EXTERNAL THREAD

NYLON -TIPPED SETSCREW
M3

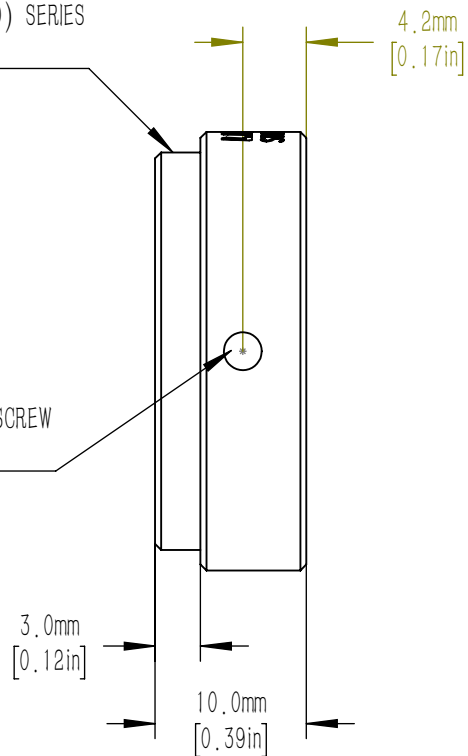

DRAWING PROJECTION			LBTEK			
	NAME	DATE	SM1-A21			
DRAWN	KZH	AUG./30th/22	LENS TUBE ADAPTER			
APPROVAL	ZXU	AUG./30th/22	MATERIAL	WEIGHT	SCALE	REV
FOR INFORMATION ONLY NOT FOR MANUFACTURING PURPOSES			N/A	0.007 Kg	2:1	B