

Ø 1.2 HOLES
FOR USE WITH OWR-U
SPANNER WRENCHES (NOT INCLUDED)
4 PLACES, 2 PER SIDE

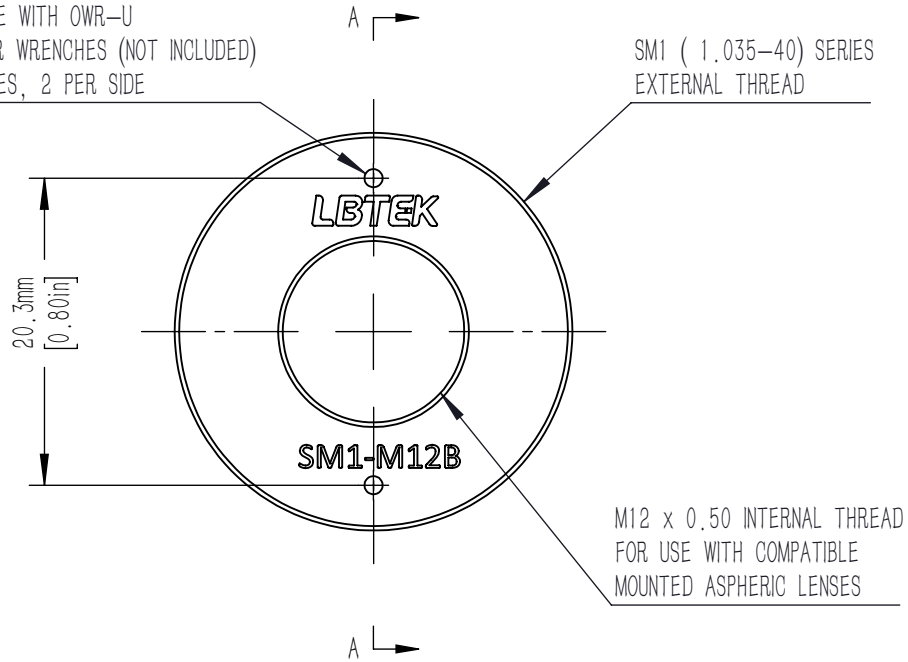

BUNA O-RING
PROVIDES FRICTION FIT
WITH MATING PARTS

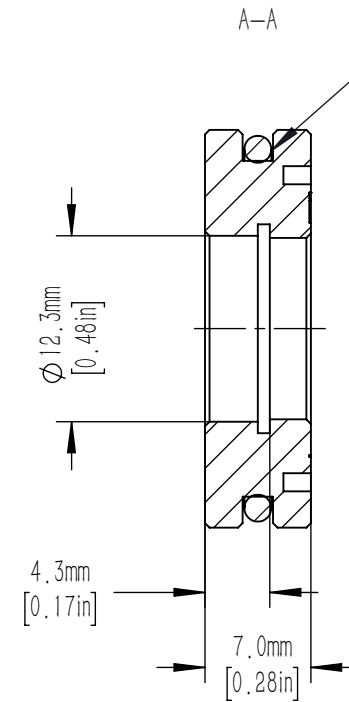

DRAWING PROJECTION			LBTEK			
	NAME	DATE	SM1-M12B			
DRAWN	SSO	MAR./6th/24	SM1 TO M12 LENS ADAPTER			
APPROVAL	HDE	MAR./6th/24	MATERIAL	WEIGHT	SCALE	REV
FOR INFORMATION ONLY NOT FOR MANUFACTURING PURPOSES			N/A	0.007 Kg	2:1	A