

SPANNER WRENCH SLOTS
FOR USING WITH OWR-U
(NOT INCLUDED)

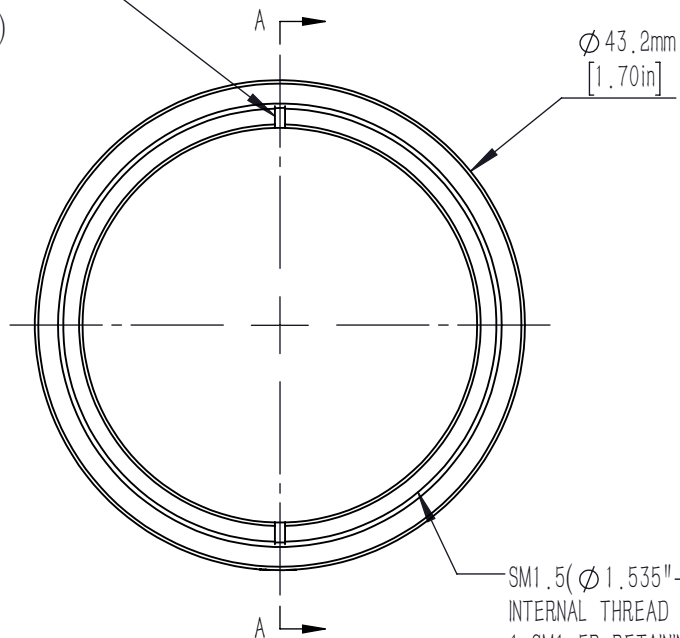

SM1.5 ($\phi 1.535''-40$) SERIES
INTERNAL THREAD
1 SM1.5R RETAINING RING INCLUDED
 $\phi 34.8\text{mm}$ [$\phi 1.37\text{in}$] CLEAR APERTURE

SM1.5 ($\phi 1.535''-40$) SERIES
EXTERNAL THREAD

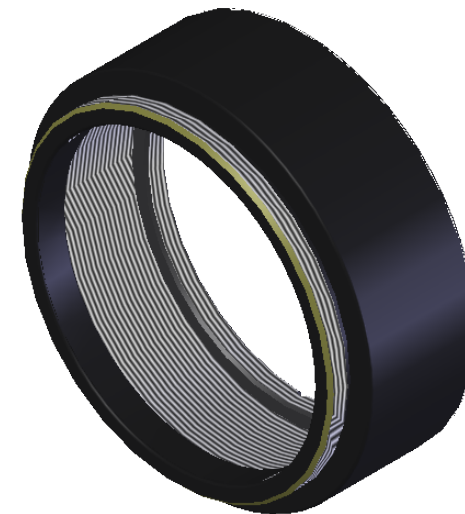
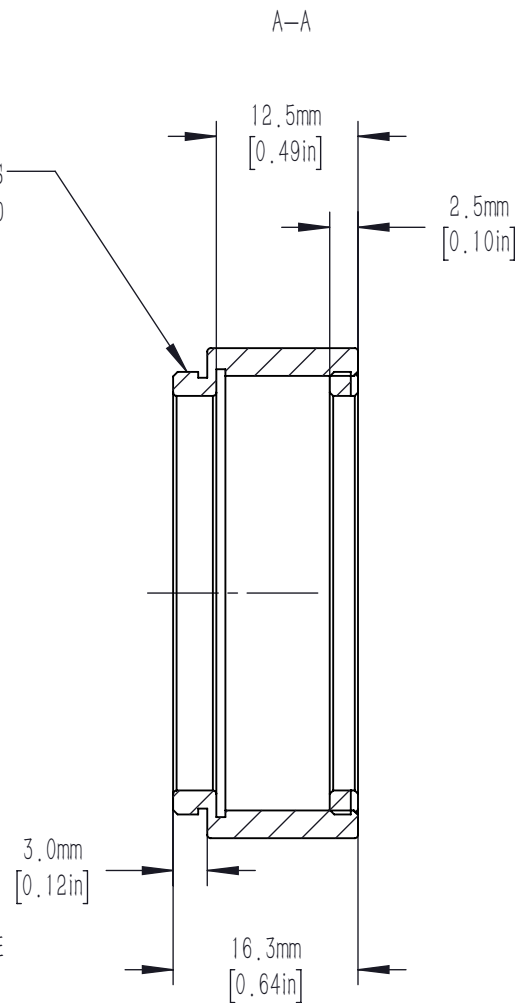

DRAWING PROJECTION			LBTEK			
	NAME	DATE	SM1.5-12.5A			
DRAWN	YCH	MAR./24th/21	SM1.5 LENS TUBE, 12.5mm DEEP			
APPROVAL	WCH	MAR./24th/21	MATERIAL	WEIGHT	SCALE	REV
FOR INFORMATION ONLY NOT FOR MANUFACTURING PURPOSES			ALUMINUM	0.018 Kg	1.5:1	B