

SPANNER WRENCH SLOTS
FOR USING WITH OWR-U
(NOT INCLUDED)

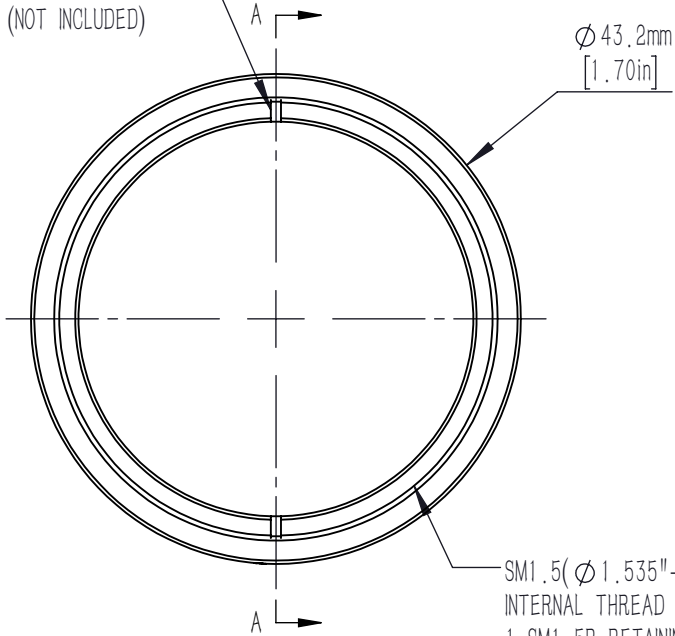

SM1.5 ($\varnothing 1.535''-40$) SERIES
EXTERNAL THREAD

$\varnothing 43.2\text{mm}$
[1.70in]

SM1.5 ($\varnothing 1.535''-40$) SERIES
INTERNAL THREAD
1 SM1.5R RETAINING RING INCLUDED
 $\varnothing 34.8\text{mm}$ [$\varnothing 1.37\text{in}$] CLEAR APERTURE

A-A

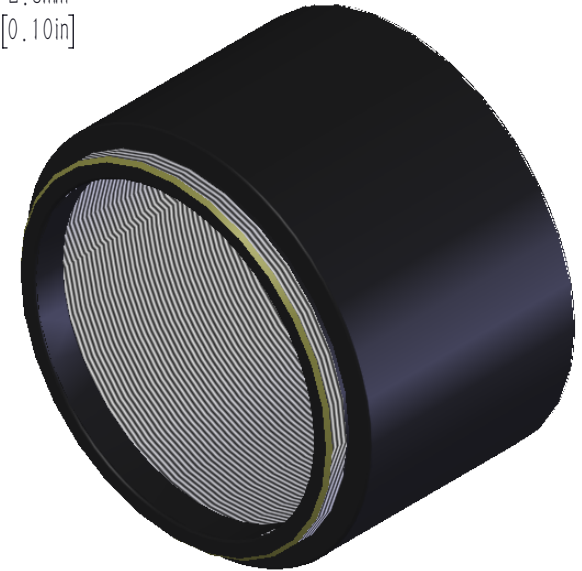
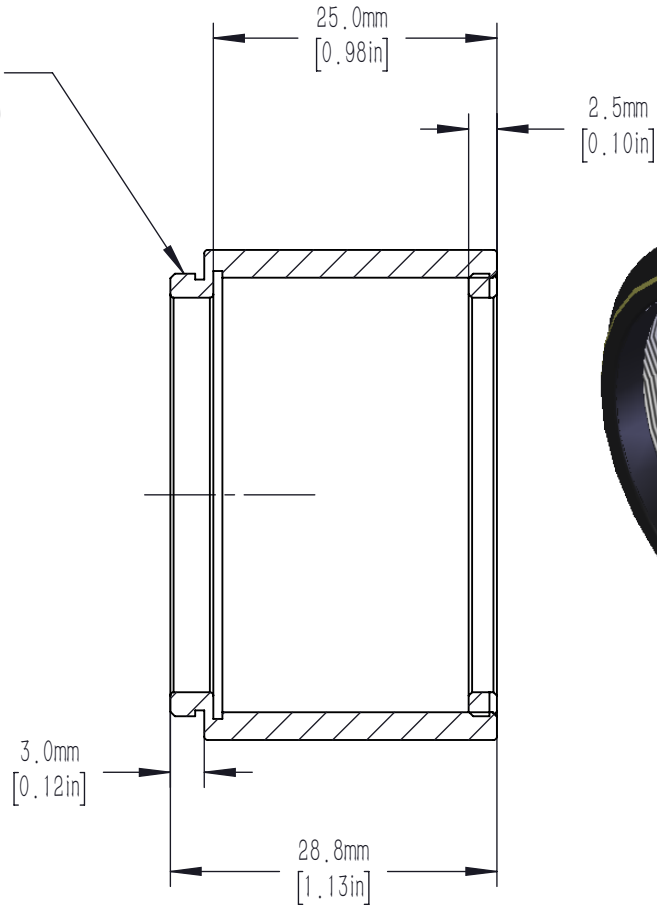

DRAWING PROJECTION			LBTEK			
	NAME	DATE				
DRAWN	YCH	MAR./24th/21	SM1.5 LENS TUBE, 25mm DEEP			
APPROVAL	WCH	MAR./24th/21	MATERIAL	WEIGHT	SCALE	REV
FOR INFORMATION ONLY NOT FOR MANUFACTURING PURPOSES			ALUMINUM	0.028 Kg	1.5:1	B