

SPANNER WRENCH SLOTS
FOR USING WITH OWR-2A
(NOT INCLUDED)

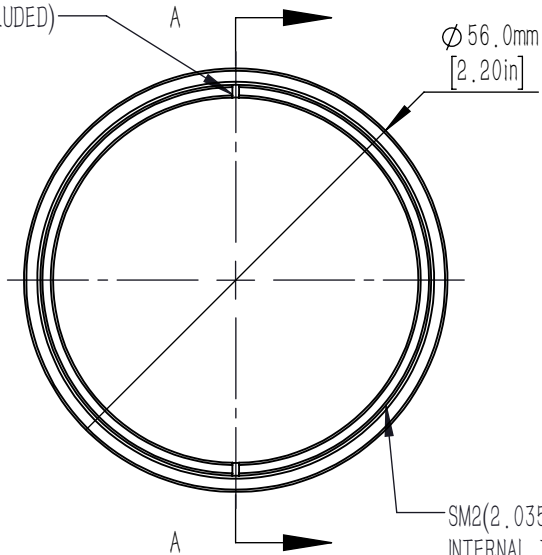

SM2(2.035-40) SERIES
INTERNAL THREAD
1 SM2RR RETAINING RING INCLUDED
 $\Phi 48.3\text{mm}$ [$\Phi 1.90\text{in}$] CLEAR APERTURE

SM2($\Phi 2.035-40$) SERIES
EXTERNAL THREAD

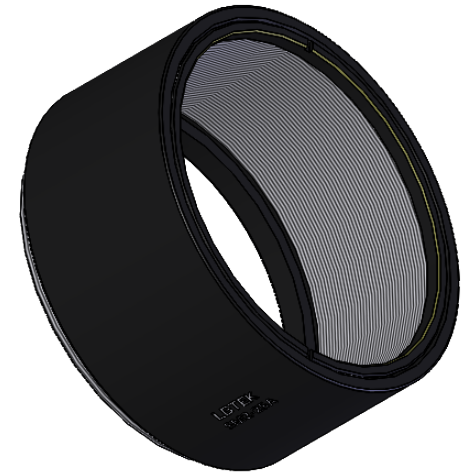
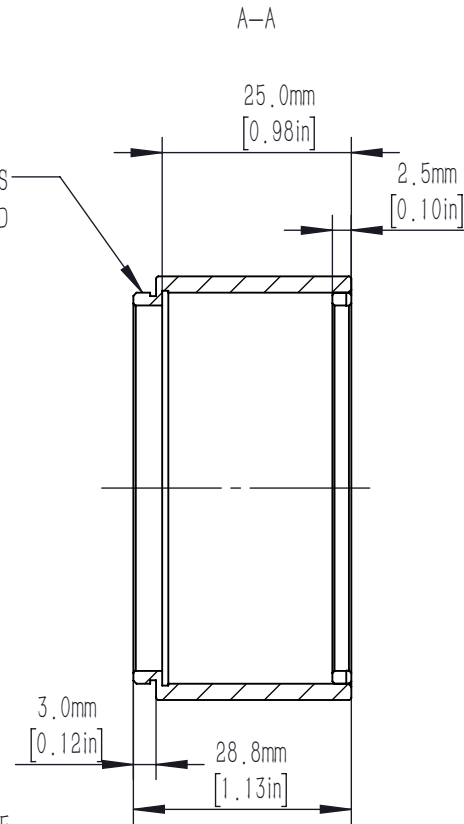

DRAWING PROJECTION			LBTEK			
	NAME	DATE				
DRAWN	BYIN	JUN./25th/19	SM2 LENS TUBE, 25mm DEEP			
APPROVAL	LDAI	JUN./25th/19	MATERIAL	WEIGHT	SCALE	REV
FOR INFORMATION ONLY NOT FOR MANUFACTURING PURPOSES			ALUMINIUM	0.09 Kg	1:1	B