

COUNTERBORED
FOR USE WITH M4 CAP SCREW

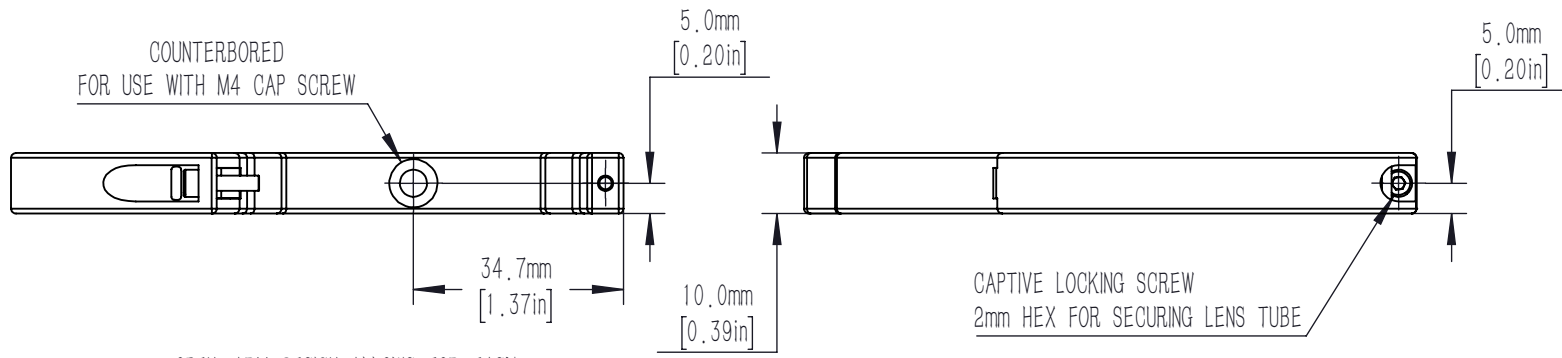

OPEN-ARM DESIGN ALLOWS FOR EASY
DROP-IN INSTALLATION & REMOVAL
OF LENS TUBE FROM OPTICAL SETUP

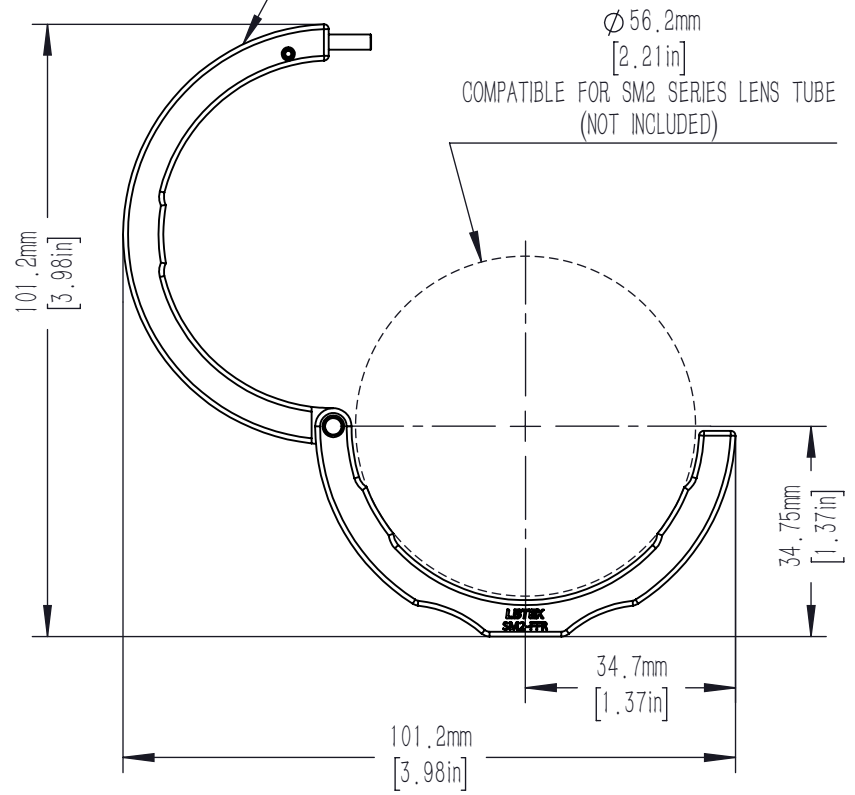

COMPATIBLE FOR SM2 SERIES LENS TUBE
(NOT INCLUDED)

CAPTIVE LOCKING SCREW
2mm HEX FOR SECURING LENS TUBE

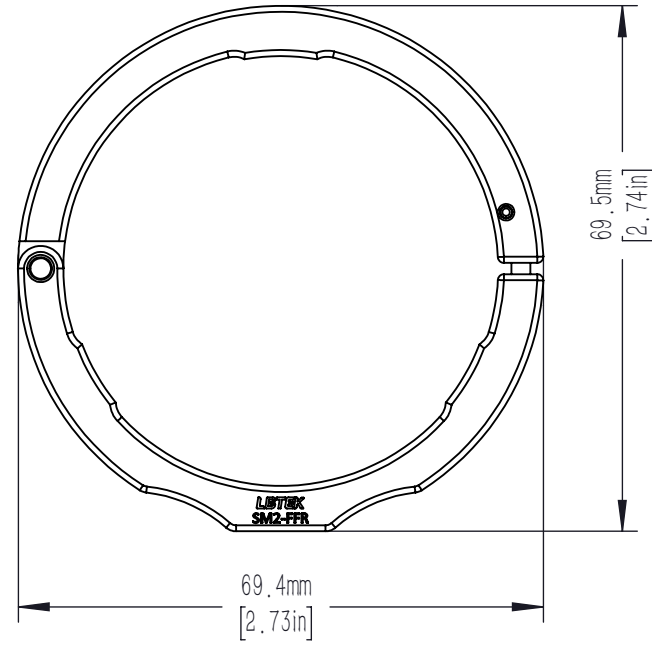

CLOSED VIEW



DRAWING PROJECTION			LBTEK			
NAME	DATE	SM2-FFR				
DRAWN	HDE	July./28th/21	SM2 SERIES TUBE CLAMP			
APPROVAL	ZXU	July./28th/21	MATERIAL	WEIGHT	SCALE	REV
FOR INFORMATION ONLY NOT FOR MANUFACTURING PURPOSES			ALUMINUM	0.031 Kg	4:5	B