

FOR INFORMATION ONLY  
NOT FOR MANUFACTURING PURPOSES

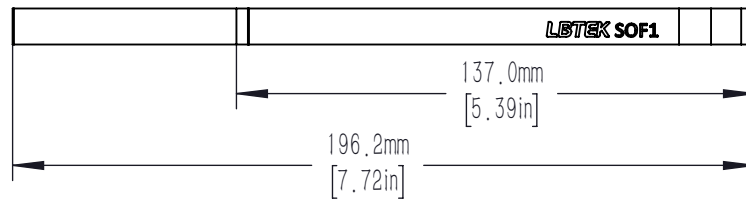

M3 MOUNTING THRU HOLES  
FOR USE WITH MOP SERIES RODS  
4 PLACES, BOTH SIDES

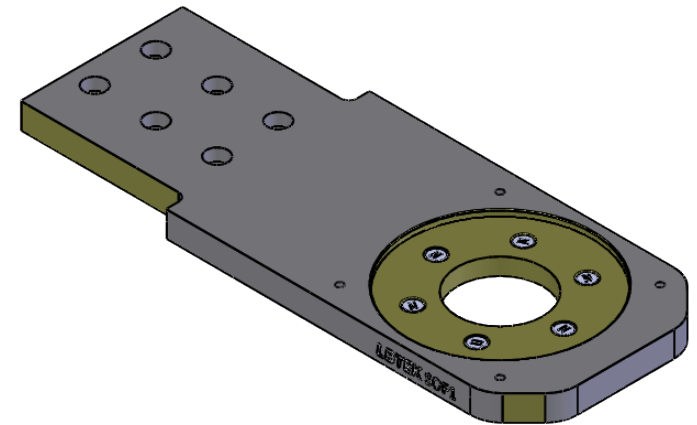
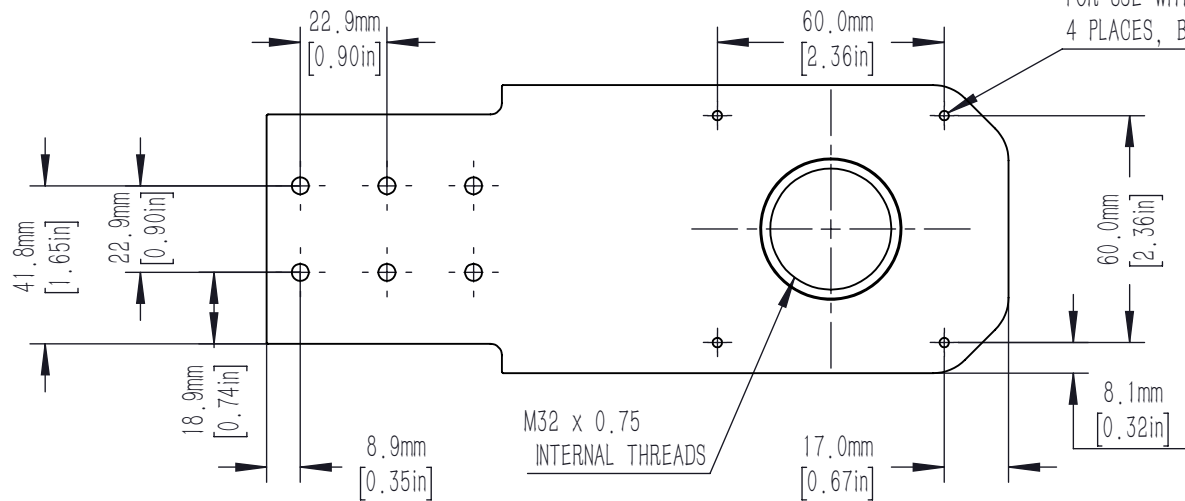

DRAWING PROJECTION							
	NAME	DATE	SOF1				
DRAWN	PCH	AUG./13th/25	SINGLE OBJECTIVE ARM, M32 X 0.75 THREADS				
APPROVAL	YLI	AUG./13th/25	MATERIAL	WEIGHT	SCALE	REV	
FOR INFORMATION ONLY NOT FOR MANUFACTURING PURPOSES			N/A	0.309 Kg	1:2	A	