

AUX 0° POSITION

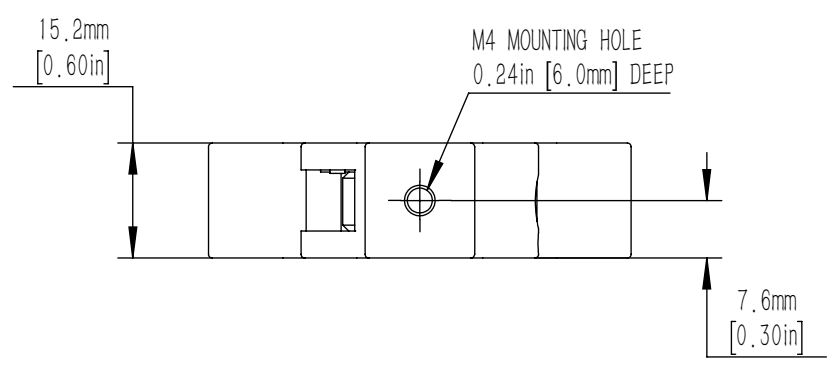

| | | | | | | |
|--|------|--------------|----------------|----------|-------|-----|
| DRAWING PROJECTION | | | LBTEK | | | |
| | NAME | DATE | | | | |
| DRAWN | HDE | Aug./30th/22 | 90° FLIP MOUNT | | | |
| APPROVAL | ZXU | Aug./30th/22 | MATERIAL | WEIGHT | SCALE | REV |
| FOR INFORMATION ONLY NOT FOR MANUFACTURING PURPOSES | | | ALUMINUM | 0.057 Kg | 1:1 | B |