

VIEW A

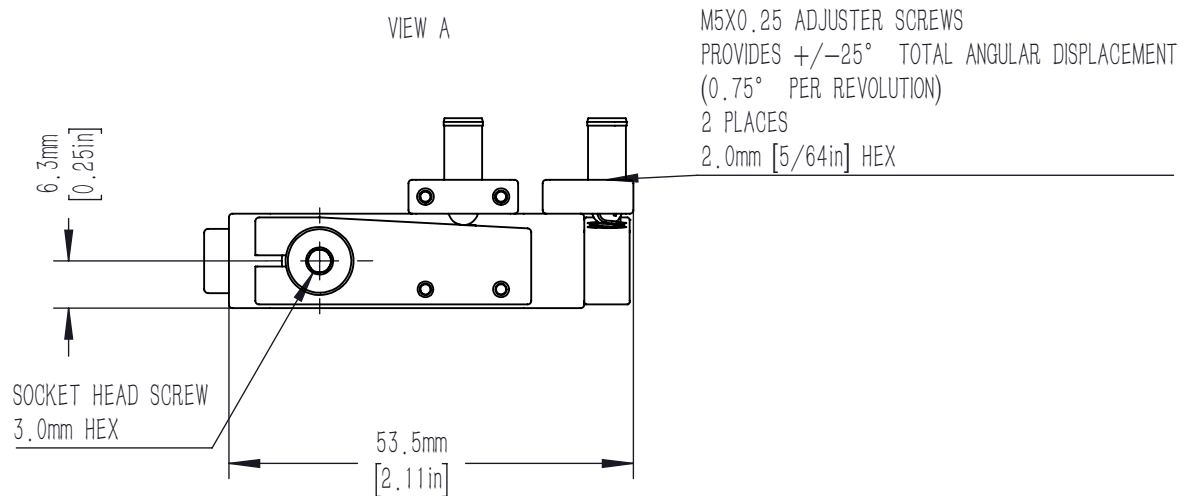

DRAWING PROJECTION			LBTEK			
	NAME	DATE	UAMC-1A			
DRAWN	CZH	MAR./6th/20	UNIVERSAL ADJUSTMENT FRAM			
APPROVAL	ZXU	MAR./6th/20	MATERIAL	WEIGHT	SCALE	REV
FOR INFORMATION ONLY NOT FOR MANUFACTURING PURPOSES			N/A	0.073 Kg	1:1	B