

NOTES

1. DESIGN WAVELENGTH: 1064 nm
2. TRANSMITTED BEAM DEVIATION:  $\pm 5$  arcmin
3. CLEAR APERTURE:  $\varnothing 10$  mm

BEAMSPLITTER:

4. SURFACE QUALITY: 20/10(S/D)
5. EXTINCTION RATIO:  $T_p/T_s > 2000:1$
6. WAVEFRONT ERROR(RMS):  $< \lambda/4 @ 632.8$  nm
7. COATING(ALL 4 OUTER OPTICAL SURFACES):  
V Coating@1064 nm, Rabs:  $< 0.25\%$ ,  $0^\circ$  AOI

WAVEPLATE

8. SURFACE QUALITY: 40/20(S/D)
9. DELAY:  $\lambda/4$
10. DELAY TOLERANCE:  $\pm \lambda/100$
11. WAVEFRONT ERROR(RMS):  $< \lambda/4 @ 632.8$  nm
12. AR COATING:  $R_{avg} < 0.5\% @ 700-1100$  nm

NUMBER	PART DESCRIPTION	MATERIAL
①	MECHANICAL HOUSING	BLACK ANODIZED ALUMINUM
②	PBS24-1064	UV FUSED SILICA
③	1064 nm $\lambda/4$ WAVEPLATE	LCP/N-BK7

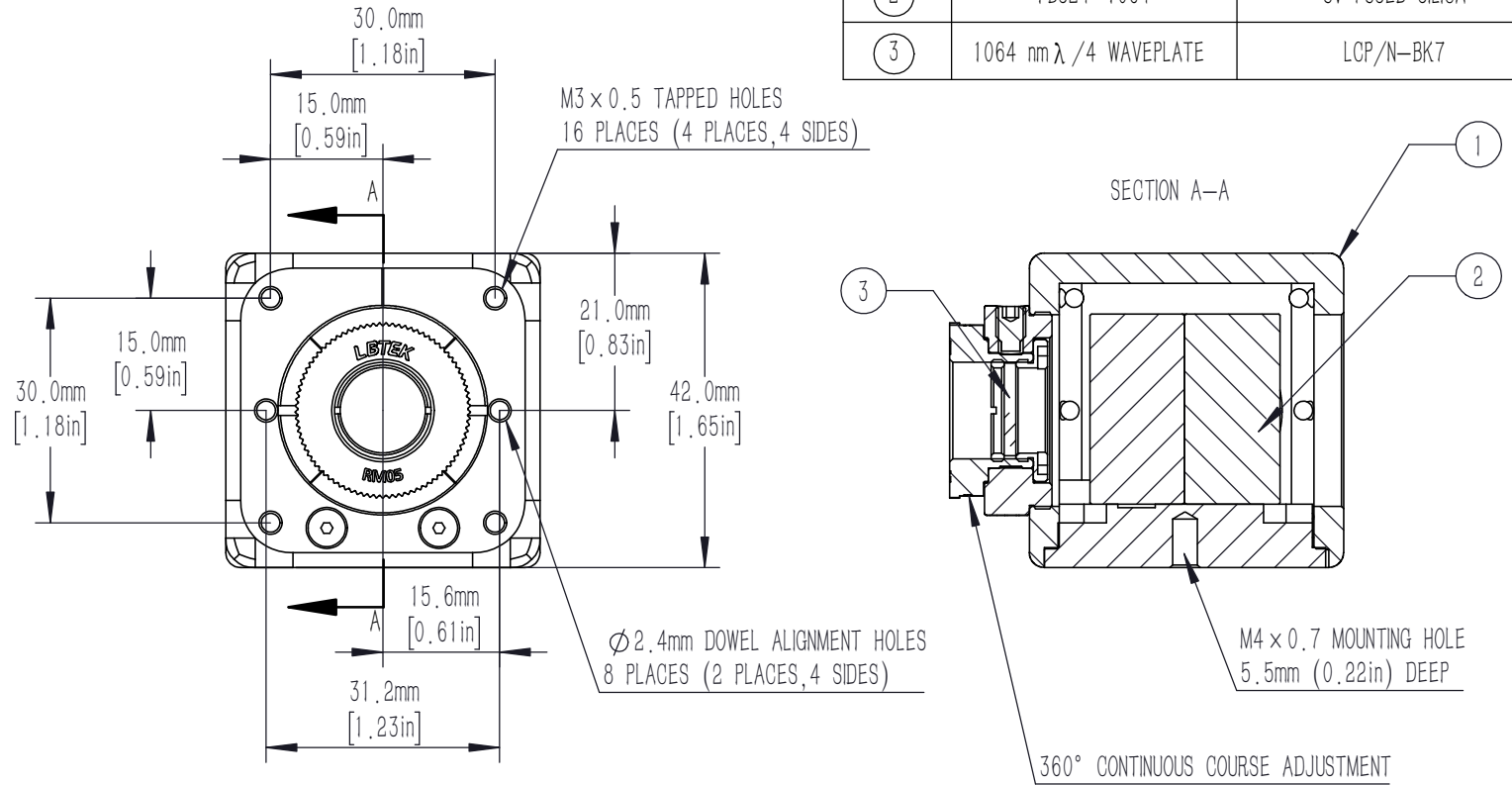

DRAWING PROJECTION				<b>LBTEK</b>			
	NAME	DATE	VCPBS24-1064				
DRAWN	LZHOU	Aug. /5th/24	VARIABLE CIRCULAR POLARIZER @1064 nm				
APPROVAL	WCHENG	Aug. /5th/24	MATERIAL	WEIGHT	SCALE	REV	
FOR INFORMATION ONLY NOT FOR MANUFACTURING PURPOSES			LCP/N-BK7 & UVFS	132 g	1:1	B	