

NOTES

- DESIGN WAVELENGTH: 1030 nm
- TRANSMITTED BEAM DEVIATION: ± 5 arcmin
- CLEAR APERTURE: $\varnothing 10$ mm

BEAMSPLITTER:

- SURFACE QUALITY: 20/10 (S/D)
- EXTINCTION RATIO: $T_p/T_s > 2000: 1$
- WAVEFRONT ERROR(RMS): $< \lambda/4$ @ 632.8 nm
- COATING (ALL 4 OUTER OPTICAL SURFACES):
V Coating@1030 nm, Rabs: $< 0.25\%$, 0° AOI

WAVEPLATE

- SURFACE QUALITY: 20/10 (S/D)
- DELAY: $\lambda/2$
- DELAY TOLERANCE: $\pm \lambda/300$
- WAVEFRONT ERROR(RMS): $< \lambda/8$ @ 632.8 nm
- AR COATING: V Coating@1030 nm, Rabs $< 0.25\%$, (6° AOI, SINGLE SURFACE)

NUMBER	PART DESCRIPTION	MATERIAL
①	MECHANICAL HOUSING	BLACK ANODIZED ALUMINUM
②	PBS24-1030-HP	UV FUSED SILICA
③	1030 nm $\lambda/2$ WAVEPLATE	QUARTZ

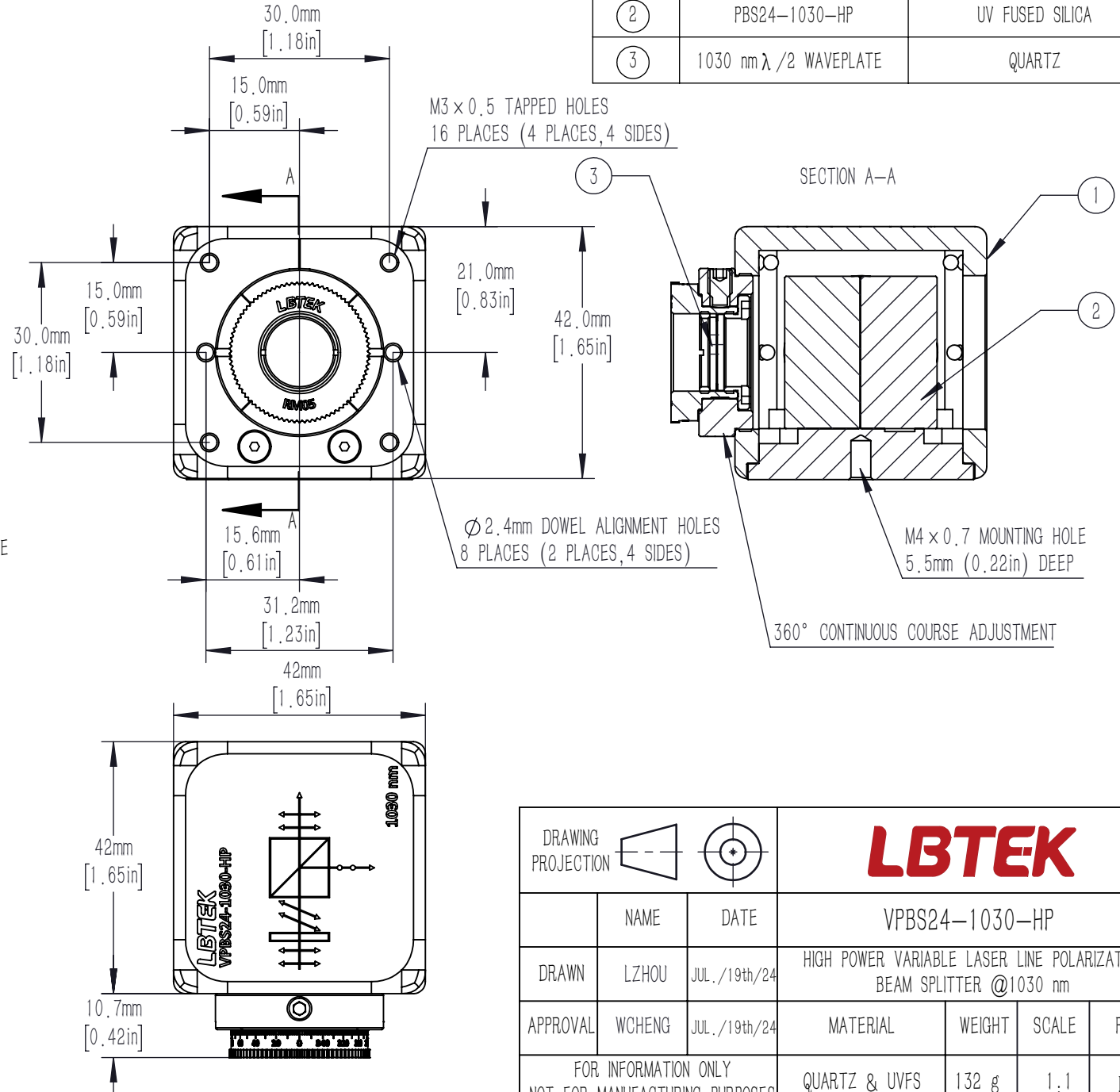

DRAWING PROJECTION							
	NAME	DATE					
DRAWN	LZHOU	JUL./19th/24		HIGH POWER VARIABLE LASER LINE POLARIZATION BEAM SPLITTER @1030 nm			
APPROVAL	WCHENG	JUL./19th/24		MATERIAL	WEIGHT	SCALE	REV
FOR INFORMATION ONLY NOT FOR MANUFACTURING PURPOSES				QUARTZ & UVFS	132 g	1:1	B