

NOTES

1. DESIGN WAVELENGTH: 780 nm
2. TRANSMITTED BEAM DEVIATION: ± 5 arcmin
3. CLEAR APERTURE: $\varnothing 10$ mm

BEAMSPLITTER:

4. SURFACE QUALITY: 20/10 (S/D)
5. EXTINCTION RATIO: $T_p/T_s > 2000: 1$
6. WAVEFRONT ERROR(RMS): $< \lambda/4$ @632.8 nm
7. COATING (ALL 4 OUTER OPTICAL SURFACES) :
V Coating@780 nm, Rabs: $< 0.25\%$, 0° AOI

WAVEPLATE

8. SURFACE QUALITY: 20/10 (S/D)
9. DELAY: $\lambda/2$
10. DELAY TOLERANCE: $\pm \lambda/300$
11. WAVEFRONT ERROR(RMS): $< \lambda/8$ @632.8 nm
12. AR COATING: V Coating@780 nm, Rabs $< 0.25\%$, (6° AOI, SINGLE SURFACE)

NUMBER	PART DESCRIPTION	MATERIAL
①	MECHANICAL HOUSING	BLACK ANODIZED ALUMINUM
②	PBS24-780-HP	UV FUSED SILICA
③	780 nm $\lambda/2$ WAVEPLATE	QUARTZ

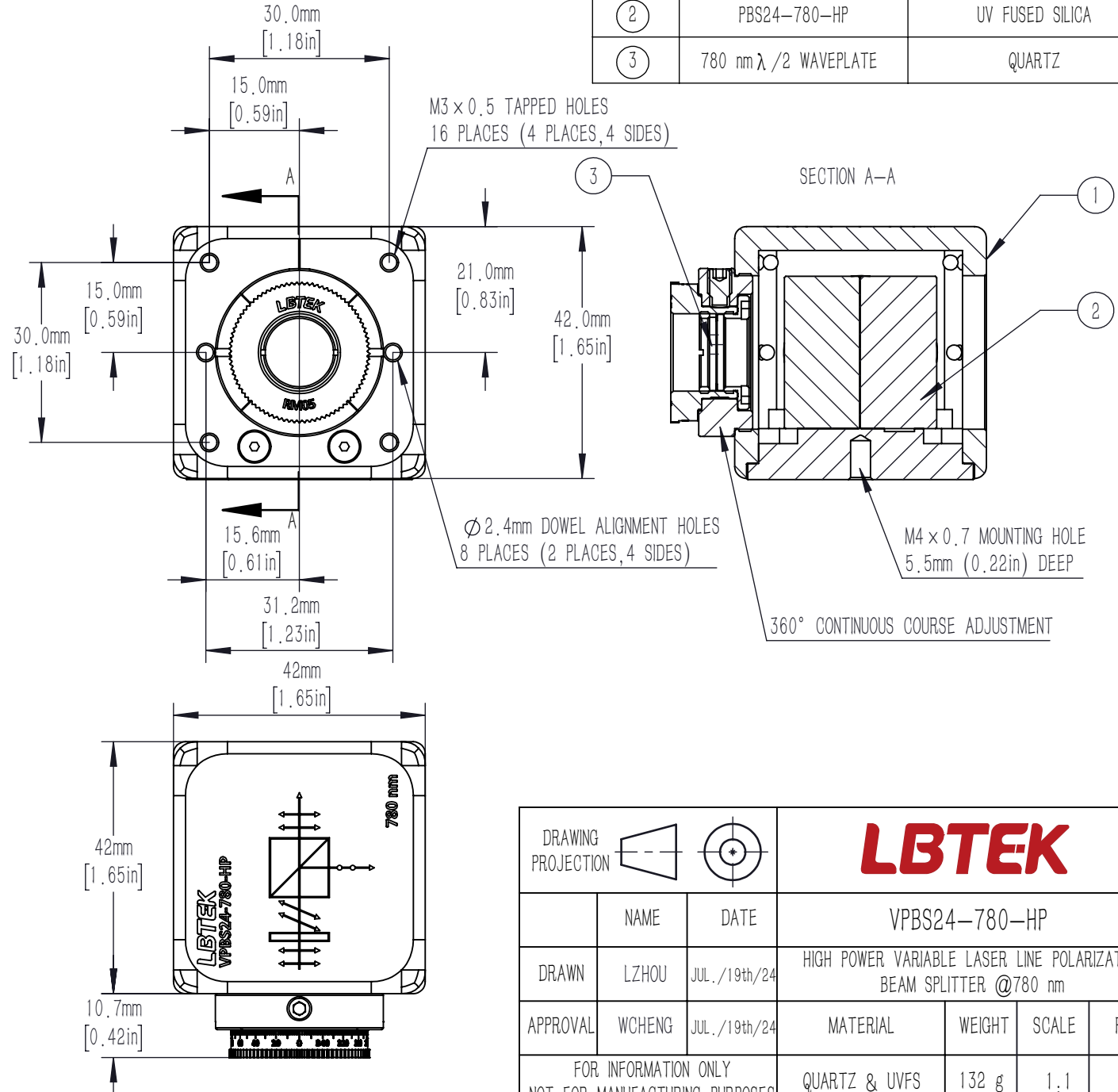

DRAWING PROJECTION				LBTEK			
	NAME	DATE	VPBS24-780-HP				
DRAWN	LZHOU	JUL./19th/24	HIGH POWER VARIABLE LASER LINE POLARIZATION BEAM SPLITTER @780 nm				
APPROVAL	WCHENG	JUL./19th/24	MATERIAL	WEIGHT	SCALE	REV	
FOR INFORMATION ONLY NOT FOR MANUFACTURING PURPOSES			QUARTZ & UVFS	132 g	1:1	B	