

B-B

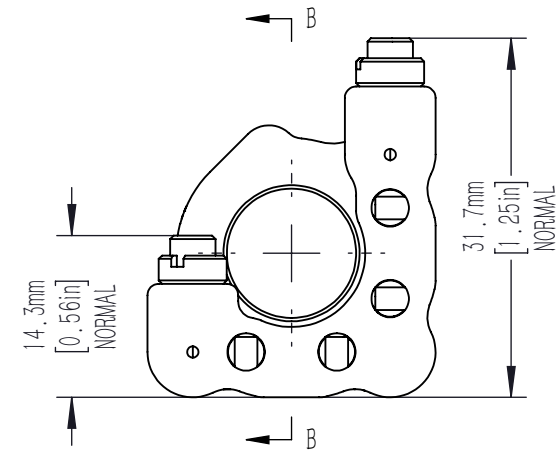
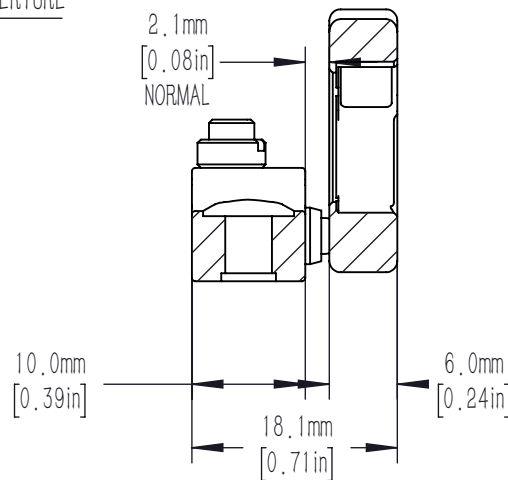

NOTE:

- 1) RECOMMENDED DOWEL PIN FOR ALIGNMENT PIN FEATURES IS A STANDARD 2mm DIN 7-m6 (ISO 2338) GROUND DOWEL PIN ( 2.002 mm TO 2.008 mm).
- 2) FOR A 2mm x 5mm PIN, WE RECOMMEND 0.0791in TO 0.0796in (2.01mm TO 2.02mm) x 0.185in ± 0.005in (4.7mm ± 0.13mm) DEEP HOLES BE MADE INTO THE MATING SURFACE FOR THE MOUNT. THE SEPARATION OF THE HOLES IN RELATION TO THE MOUNTING HOLE LOCATION SHOULD HAVE A TOLERANCE OF 0.003in(0.08mm).

DRAWING PROJECTION			<b>LBTEK</b>			
NAME	DATE	VSS-MT-AM05S5				
DRAWN	ZZH	JAN./9th/26	HEX DRIVE MIRROR MOUNT FOR 12.7mm OPTICS, VACUUM SERIES SERIES			
APPROVAL	YLI	JAN./9th/26	MATERIAL	WEIGHT	SCALE	REV
FOR INFORMATION ONLY NOT FOR MANUFACTURING PURPOSES			N/A	Kg	1.5:1	A